

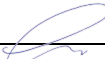

Jemena Port Kembla Pipeline Project **SOIL AND WATER MANAGEMENT SUBPLAN**

Document No.: GAS-599-PA-EV-007 | Revision 6

6	Issued for Use	BRO 	RPO 	BPH 	JHE 	30-NOV-2022
5	Issued for Use	BRO	RPO	BPH	JHE	18-NOV 2022
4	Issued for Use	BRO	HHE	BPH	JHE	18-OCT-2022
3	Issued for Use	BRO	HHE	BPH	JHE	28-SEP-2022
2	Issued for Use	BRO	HHE	BPH	JHE	19-AUG-2022
1	Issued for Use	BRO	BPH	NFU	BKE	1-AUG-2022
0	Issued for Use	BRO	ZFR	NFU	JHE	9-JUN-2022
A	Issued for Review	BRO	BPH	NFU	JHE	5-MAY-2022
Rev	Description	By	Checked	QA	Nacap Approved	Date

REVISION HISTORY

This table describes changes made for numerical revisions after Rev 0

Date	Rev	By	Description
02/08/2022	1	BRO	Implementation of Jemena and AIE comments for Approvals consultation
19/08/2022	2	BRO	Implementation of minor formatting changes only following Jemena review – CODE 2
28/9/2022	3	BRO	Updated following AIE and Site Auditor Review
15/10/2022	4	BRO	Updated following review by AIE
14/11/2022	5	BRO	Update following DPE Review
30/11/2022	6	BRO	Minor update following DPE Review

CONTENTS

ACRONYMS.....6

GLOSSARY.....8

1 INTRODUCTION10

1.1 Background 10

1.2 Purpose and Scope..... 11

 1.3 References..... 12

 1.4 Principal Contractor Details..... 12

 1.5 Environmental Management System Overview..... 12

 1.6 CEMP Structure and relationship with sub plans 12

 1.7 Objectives and Targets 13

 1.8 Consultation 14

 1.9 Certification and Approval..... 14

 1.10 Distribution..... 14

2 ENVIRONMENTAL PLANNING AND GOVERNANCE.....14

 2.1 Legislation..... 14

 2.2 Guidelines..... 15

 2.3 Conditions of Approval (CoA) requirements for SWMP 15

 2.4 Environmental Management Measures..... 19

3 EXISTING ENVIRONMENT.....22

 3.1 Site Description and Existing Land use 22

 3.2 Soils and Landforms..... 23

 3.2.1 Acid Sulfate Soils.....23

 3.2.2 Contamination25

 3.3 Climate..... 26

 3.4 Rainfall 27

 3.5 Rainfall Erosivity 27

 3.6 Temperature..... 27

 3.7 Wind 28

 3.8 Surface Water..... 28

 3.9 Groundwater 28

 3.10 Flooding 28

 3.11 Heritage 29

 3.11.1 Historical Heritage29

 3.11.2 Aboriginal cultural heritage.....29

4 CONSTRUCTION ASPECTS AND IMPACTS..... 29

 4.1 Construction Activities..... 29

 4.2 Construction Soil and Water Impacts..... 30

 4.3 Spoil Management 31

 4.4 Erosion and Sedimentation 32

 4.5 Spills and Incidents 32

4.6	Pollution	32
4.7	Unexpected Contamination	33
4.8	Unexpected Heritage.....	33
4.9	Water Sources	33
4.10	Dewatering and Water Reuse	33
4.11	Wastewater	33
5	CONSTRUCTION CONTROLS.....	33
5.1	Roles and Responsibilities	33
5.2	Training and Awareness	34
5.3	Construction Soil and Water Management Measures.....	35
6	MONITORING AND INSPECTIONS.....	41
7	RECORD KEEPING AND REPORTING.....	42
7.1	Record Keeping	42
7.2	Reporting.....	42
	7.2.1 Environmental Incident Reporting	42
	7.2.2 POEO Act Incident Notification	42
8	REVIEW AND IMPROVEMENT.....	43
APPENDIX A	CONSULTATION RECORD.....	44
APPENDIX B	SPOIL MANAGEMENT PROTOCOL.....	45
APPENDIX C	EROSION AND SEDIMENT CONTROL PLAN.....	47
APPENDIX D	UNEXPECTED CONTAMINATED LAND FINDS PROCEDURE.....	48
APPENDIX E	UNEXPECTED HERITAGE & HUMAN REMAINS PROCEDURE.....	49
APPENDIX F	DEWATERING AND WATER REUSE PROTOCOL.....	50
APPENDIX G	ACID SULFATE SOILS MANAGEMENT PLAN.....	52

LIST OF FIGURES

Figure 1 - Project Layout.....	10
Figure 2 – Location of Boreholes to inform the EA	25

LIST OF TABLES

Table 1 – Emergency and Key Contacts	5
Table 2 – Acronyms	6
Table 3 – Glossary.....	8
Table 4 - SWMP scope relevant to SS1-9471 and SSI-9973	11
Table 5 - Reference Documents	12
Table 6 - Principal Contract Details.....	12
Table 7 - Objectives and Targets	13
Table 8 - Conditions of Approval requirements SWMP	15
Table 9 – Environmental Management Measure (EMM) requirements SWMP	19
Table 10 – Port Kembla Rainfall Data (mm).....	27
Table 11 – R- Factor and RUSLE Factor Assessment	27
Table 12 – Port Kembla Temperature Data (°C)	27
Table 13 – Port Kembla Wind Data (km/h).....	28
Table 14 – Nacap Environmental Management Responsibilities	33
Table 15 – Construction Soil and Water Management Measures.....	35

LIST OF EMERGENCY AND KEY CONTACTS

Table 1 – Emergency and Key Contacts

Organisation/Position	Contact Details
Environment Line (EPA Pollution Hotline)	131 555 The Environment Line handles general inquiries about environmental issues and takes reports of pollution for which the EPA has regulatory responsibilities. Environment Line is a one-stop pollution and environmental incident reporting service provided by Environment and Heritage Group (EEG) and EPA.
Fire and Rescue NSW	000 (for pollution incidents that present an immediate threat to human health or property) 1300 729 579 (for pollution incidents that do not present an immediate threat to human health or property)
Wollongong City Council	General Enquiries (02) 4227 7111
NSW Ports	General Enquiries 1300 922 524
Port Authority NSW	24-hour community enquiries and complaints line (02) 9296 4962 enquiries@portauthoritynsw.com.au
Port Kembla Coal Terminal	Administration (02) 4228 0288
BlueScope	Laura Davis Laura.davis@bluescopesteel.com +61 467728547
Transport for NSW	General Enquiries (02) 8202 2200
GrainCorp	Dylan Clarkson +61 409 739 697 dclarkson@graincorp.com.au

Organisation/Position	Contact Details
AIE	Andrew Petch +61 401 175 917 Andrew.petch@ausindenergy.com
Jemena	Community Feedback - 1300 081 989 Justin Anderson 0435 092 889 justin.anderson@zinfra.com.au
Nacap	Jason Heard Nacap Project Manager j.heard@nacap.com.au +61 488 087 393

ACRONYMS

Table 2 – Acronyms

Term	Meaning
ACM	Asbestos containing material
AHIMS	Aboriginal Heritage Information Management System
AIE	Australian Industrial Energy
APGA	Australian Pipelines and Gas Association
AQMP	Air Quality Management Plan
ASS	Acid Sulfate Soils
ASSMAC	Acid Sulfate Soils Management Advisory Committee
ASSMP	Acid Sulfate Soils Management Plan
BCD	Biodiversity Conservation Division
BPESC	Best Practice Erosion and Sediment Control
CEMP	Construction Environmental Management Plan
CoA	Conditions of Approval

Term	Meaning
CROW	Construction Right-of-Way
DPIE	Department of Planning, Industry and Environment
DSITAI	Queensland Department of Science, Information Technology and Innovation
EA	Environmental Assessment
EES	Environment Energy and Science
EGP	Eastern Gas Pipeline
EIS	Environmental Impact Statement
EOL	End of Line
EMM	Environmental Management Measures
EPA	Environment Protection Agency
ERP	Emergency Response Plan
ESC	Erosion and Sediment Control
ESCP	Erosion and Sediment Control Plan
FSRU	Floating Storage and Regasification Unit
HDD	Horizontal Directional Drilling
IECA	International Erosion Control Association
ISO	International Standards Organisation
KGMS	Kembla Grange Meter Station
LECH	Land, Environment and Cultural Heritage
LNG	Liquid Natural Gas
MIJ	Monolithic Insulating Joint
NATA	National Association of Testing Authorities
NEPC	National Environmental Protection Council

Term	Meaning
NEPM	National Environmental Protection Measure
NSW	New South Wales
PASS	Potential Acid Sulfate Soils
PKGT	Port Kembla Gas Terminal
PKL	Port Kembla Lateral
PKPP	Port Kembla Pipeline Project
POEO Act	Protection of Environment Operations Act 1997
Principal	Jemena
QLD	Queensland
RAP	Remediation Action Plan
SOW	Scope of Work
SSI	State Significant Infrastructure
SWMP	Soil and Water Management Plan (This Plan)
SWMS	Safe Work Method Statements
TfNSW	Transport for NSW
UFP	Unexpected Finds Protocol
WMP	Waste Management Plan

GLOSSARY

Table 3 – Glossary

Term	Meaning
Company/Principal	Jemena
Contractor	Nacap

Term	Meaning
Environmental Assessment	Includes the following EIS and Modification Reports: > Port Kembla Gas Terminal EIS and Modifications 1, 2 and 3, and Eastern Gas Pipeline EIS and Modifications 1 and 2.
Hazard	A source or a situation with a potential for harm in terms of human injury or ill-health, damage to property, damage to the environment, or a combination.
HAZID	Hazard Identification risk assessment
Incident	A set of circumstances that: > causes or threatens to cause material harm to the environment; and/or > breaches or exceeds the limits or performance measures/criteria in this approval
Project	Port Kembla Pipeline
Regulatory Requirements	Government acts and regulations that are environment specific which prescribe legal obligations encompassing the employer and contractor.
Risk	Effect of uncertainty on objectives. Often expressed in terms of a combination of the consequences of an event (including changes in circumstances) and the associated likelihood of occurrence [ISO Guide 73:2009, definition 1.1]
Sensitive Receptor	Locations where people are likely to work or reside and be affected by the works. May include residential dwellings, places of work, places of worship and areas of public open space used for recreation and access
Spoil	Excavation material including rock and material other than rock but excluding topsoil.
Stakeholder	Party with vested interest in the works
Third Party	Any party external to the works that has been identified as a stakeholder

1 INTRODUCTION

1.1 Background

Australian Industrial Energy (AIE) have approval to build a new Liquid Natural Gas (LNG) import terminal at the Port Kembla inner harbour with the aim to sell gas to the east coast market. The gas is planned to be processed on a Floating Storage and Regasification Unit (FSRU) and imported into the existing gas networks through a new pipeline that will connect the AIE Port Kembla Gas Terminal (PKGT) with the Jemena owned gas transmission network via the Eastern Gas Pipeline (EGP).

In February 2021, Jemena and AIE entered into a Project Development Agreement to enable Jemena to build, own and operate a segment of the pipeline that is approved as part of AIE’s SSI 9471 Infrastructure Approval for the PKGT, and build and operate the remainder of the pipeline approved under the same Infrastructure Approval, SSI 9471.

The Port Kembla Pipeline Project (PKPP) involves the construction of an approximately 12.1 kilometres long, 18” (DN450) buried steel gas transmission pipeline and a new End of Line (EOL) facility in the vicinity of the Jemena’s existing Kembla Grange Metering Station (KGMS) facility. The proposed PKPP Project is comprised of three sections (refer to Figure 1):

- > Segment 1.1 – 4.3 km pipeline from PKGT to Springhill Road to be built by Jemena; owned by AIE with some services provided in operation by Jemena.
- > Segment 1.2 – 2.2 km pipeline from Spring Hill Road to Five Islands Road to be built, owned, and operated by Jemena.
- > Segment 2 – 5.6 km pipeline from Five Islands Road to KGMS which includes the Kembla Grange Tie-in Facility to be built, owned and operated by Jemena.

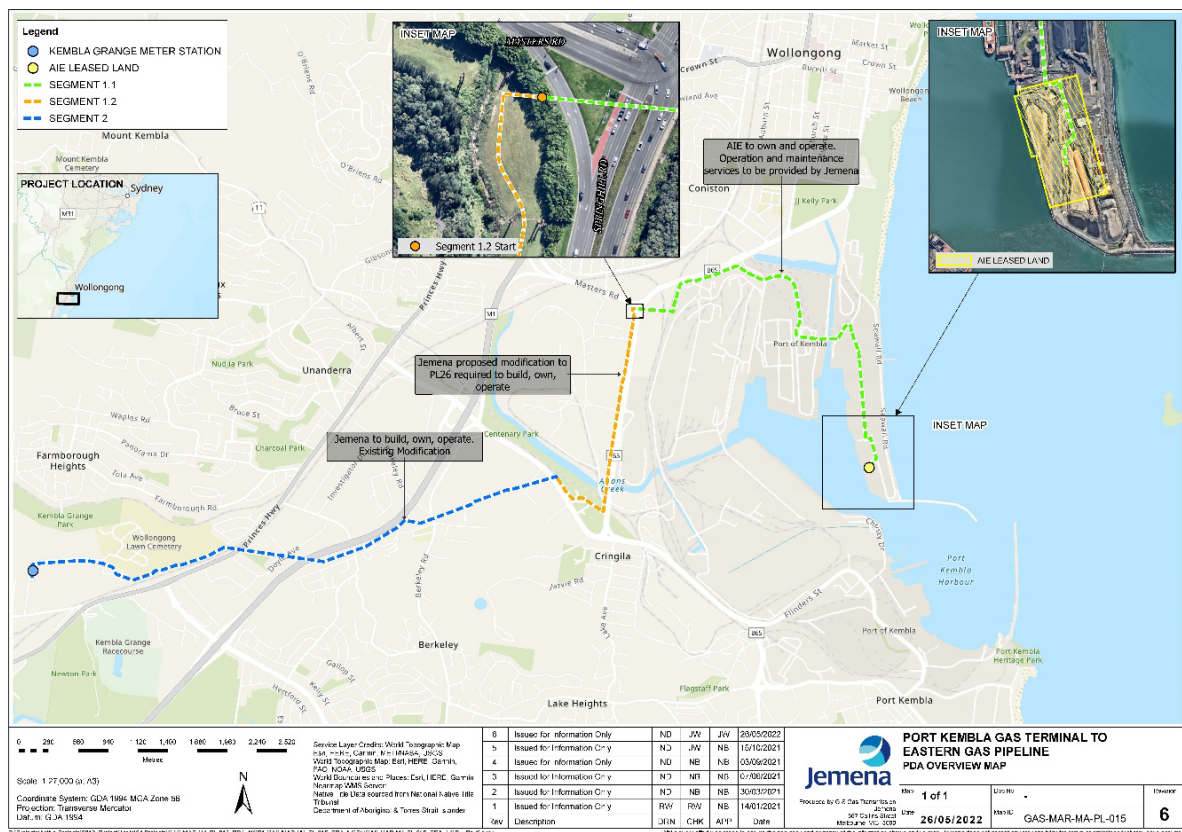

Figure 1 - Project Layout

The project is approved by the Department of Planning and Environment (DPE) under a number of Infrastructure Approvals:

- > SSI-9471 Port Kembla Gas Terminal Infrastructure Approval under Section 5.19 of the Environmental Planning and Assessment Act 1979 which incorporates Segment 1.1 and 1.2.
- > SSI-9973 Eastern Gas Pipeline Modification 1 - Port Kembla Lateral Pipeline Infrastructure Approval under section 5.25 of the Environmental Planning and Assessment Act 1979 pertains to Segment 2.
- > SSI-9973 Eastern Gas Pipeline Modification 2 - Transfer of Pipeline Segment to transfer Segment 1.2 from AIE SSI-9471 PKGT Infrastructure Approval.
- > Proposed Modification to the AIE SSI-9471 Port Kembla Gas Terminal to remove segment 1.2 from the Infrastructure Approval in Q2 2022.
- > Staging Plan approved by DPE for SSI-9471
 - o Stage 1: Early Enabling Works commenced in May 2021
 - o Stage 2a: Marine Berth Construction – Land Based commenced January 2022
 - o Stage 2b: Marine Berth Construction and Dredging – Land and Marine based commenced March 2022, and
 - o Stage 3: Pipeline installation including ties ins, proposed to commence in June 2022.
- > Staging Plan approved by DPE for SSI-9973
 - o Stage 1: Pipeline installation, and
 - o Stage 2: Construction of the tie in facilities including Kembla Grange Metering Station (KGMS).

1.2 Purpose and Scope

This Soil and Water Management Plan (SWMP) has been prepared to ensure construction activities are carried out in accordance with the Conditions of Approval (CoA), relevant regulatory requirements, standards, procedures and current best practice to ensure that all reasonable and practical measures are implemented to minimise the potential for soils, contamination and water related impacts.

This SWMP adopts an integrated approach, considering and identifying management measures overarching the sequencing of construction related activities. All works are to be implemented in accordance with the management measures and strategies contained within this plan.

This SWMP has been prepared to satisfy the requirements of both SSI 9471 and SSI 9973, the Project EIS and subsequent modification reports to include the staging of works as described above in Section 1.1 and as presented in table 4 below. This SWMP applies to the Construction phase of the works only and in accordance with the CoA will be implemented during construction.

Table 4 - SWMP scope relevant to SSI-9471 and SSI-9973

Infrastructure Approval	Post Consent Stage	Description of Works	Segment of Works As detailed in Sect 1.4 and Figure 1
SSI-9471	Stage 3	Pipeline construction from PKGT to KGMS	Segment 1.1
SSI-9973	Stage 1		Segment 1.2
			Segment 2

1.3 References

The following are principal documents referenced in this document:

Table 5 - Reference Documents

Document No.	Title of Document
GAS-554-AC-PM-001	SSI 9471 - Port Kembla Gas Terminal - Infrastructure Approval
GAS-556-AC-PM-001	SSI 9973 - Port Kembla Lateral Looping Pipeline – Infrastructure Approval including Modification 2
GAS-556-SP-PL-007	Construction Specification
GAS-551-SW-PL-001	Pipeline Construction Scope of Work
GAS-599-PA-HSE-004	Environmental Management Plan
GAS-599-PA-RA-001	Joint Post-Approval Strategy - AIE's Port Kembla Gas Terminal to Jemena's Eastern Gas Pipeline
GAS-599-RP-RA-007	Eastern Gas Pipeline - Port Kembla Lateral Looping Modification Report
GAS-599-RP-RA-008	Eastern Gas Pipeline Modification 2 - Modification Report
	Port Kembla Gas Terminal Environmental Impact Statement
GAS-556-RP-GI-001	Geotechnical and Contamination Site Investigation Report 2021

1.4 Principal Contractor Details

Table 6 - Principal Contract Details

Nacap Details	
Business name:	Nacap Pty Ltd
Address:	Ground Floor, 599 Doncaster Road, Doncaster Victoria 3108
ABN:	33 006 306 994
Main phone number:	03 8848 1888
Contact person:	Jason Heard Nacap Project Manager
Contact mobile:	+61 488 087 393
Contact email:	j.heard@nacap.com.au

1.5 Environmental Management System Overview

The environmental management system overview is described in Section 4.1 of the Construction Environmental Management Plan (CEMP) (GAS-599-PA-EV-001). This SWMP used together with the CEMP, and subordinate project documents, procedures, resources, and practices will inform and guide Nacap personnel and subcontractors to ensure that all reasonable and practical measures are taken to manage the environmental risks for the Project.

1.6 CEMP Structure and relationship with sub plans

The CEMP comprises three sections:

- > PART A: Provides background information and the overarching systems approach to environmental management and mitigation controls for the project
- > PART B: Comprising Appendices in support of PART A, and

- > PART C: Comprising the required series of environmental management sub-plans outlined in the CoA including:
 - (a) Noise Management Plan (GAS-599-PA-EV-004)
 - (b) Air Quality Management Plan (GAS-599-PA-EV-005)
 - (c) Biodiversity Management Plan (GAS-599-PA-EV-006)
 - (d) Soil and Water Management Plan (GAS-599-PA-EV-007) (this plan)**
 - (h) Traffic Management Plan (GAS-599-PA-CN-002), and
 - (i) Waste Management Plan (GAS-599-PA-EV-008).

The sub plans are structured to incorporate mitigation and control measures in meeting the project’s environmental risk assessment and includes, construction Activity Specific Environmental Management Measures and Aspect Specific Environmental Management Measures, each of which identifies the following:

- > Environmental aspects
- > Environmental performance objectives and standards
- > Measurement criteria
- > Management measures and responsibilities
- > Compliance monitoring, and
- > Records.

1.7 Objectives and Targets

The objectives and targets for the PKPP Project to be undertaken in relation to the soil and water management are listed in Table 7 Objectives and Targets.

Table 7 - Objectives and Targets

Objective	Target
Project construction activities minimise long term impacts to soil and water quality	Pre-construction soil and water quality is maintained or improved.
Ensure all personnel, subcontractors and visitors are inducted, consulted and receive regular updates and information on project soil and water aspects and impacts for the duration of works.	100% completion of Inductions, Daily Pre-Start Inputs by Environment Team, and Monthly toolbox inputs by Environment Team.
Ensure that personnel and subcontractors are aware of environmental hazards and risks associated with construction activities and relevant scope of work under the contract.	100% attendance recorded at SWMS workshops, and 100% Project Induction.
To conduct construction activities in compliance with all relevant approvals and environmental legislation.	100% compliance No regulatory infringements, including Provisional improvement notices and prosecutions.

Objective	Target
Promote a positive reporting culture. To minimise the occurrence and severity of environmental incidents during construction activities.	All environmental incidents to be reported within 2 hours and investigated appropriately.
Ensure all corrective actions are closed out by the nominated due dates	No corrective actions outstanding past due date >7 days

1.8 Consultation

Consultation on this SWMP has been undertaken with the following stakeholders:

- > Transport for NSW (TfNSW)
- > Wollongong City Council
- > NSW Ports
- > Port Authority of NSW
- > EPA
- > DPE Water, and
- > EPA accredited contaminated site auditor.

Comments and feedback received during consultation have been incorporated into the Plan where relevant before being submitted to the DPE for approval.

Details of the Consultation associated with this Plan are presented in Appendix A.

1.9 Certification and Approval

This SWMP is required to be submitted for approval by the Secretary of the DPE prior to commencement of construction or as otherwise agreed by the Secretary.

1.10 Distribution

A controlled hard copy of this SWMP and supporting documentation will be maintained and reside at the Project construction site office. Registered copies of this SWMP and supporting documentation will be distributed to the Project team, the DPE, all relevant personnel and interested third parties as required. It will also be available to view on the Project website

<https://jemen.com.au/pipelines/eastern-gas-pipeline>

<https://ausindenergy.com>

2 ENVIRONMENTAL PLANNING AND GOVERNANCE

2.1 Legislation

The legislation relevant to this SWMP is outlined in Section 3.2 of the CEMP.

2.2 Guidelines

The main guidelines, specifications and policy documents relevant to this SWMP include:

- > Australian and New Zealand Guidelines for Fresh and Marine Water Quality (2018).
- > Managing Urban Stormwater: Soils and Construction. Landcom, (4th Edition) March 2004 (reprinted 2006) (the “Blue Book”). Volume 1 and Volume 2. - Volume 2A.
- > Best Practice Erosion and Sediment Control (BPESC) (IECA 2008)1.
- > Appendix P (Pipelines). (IECA 2015)
- > National Acid Sulfate Soils Guidance A synthesis. Water Quality Australia, June 2018
- > Queensland Acid Sulfate Soil Technical Manual: Soil Management Guidelines. DSITAI (QLD), 2014.
- > Acid Sulfate Soil Manual (Acid Sulfate Soil Management Advisory Committee, 1998
- > National Environmental Protection (Assessment of site Contamination) Measure 1999 (as amended 2013) (NEPC, 2013)
- > National Environment Protection (Assessment of Site Contamination) Measure 1999
- > NSW EPA (2014a). Waste Classification Guidelines Part 1: Classification of Waste (NSW EPA, 2014)
- > NSW EPA (2014b). Waste Classification Guidelines Part 4: Acid sulfate soils (NSW EPA, 2014)
- > NSW EPA Sampling Design Guidelines (NSW EPA 2022)

2.3 Conditions of Approval (CoA) requirements for SWMP

This Plan has been prepared to comply with the Joint Post Approval Strategy for SSI-9471 (GAS-554-AC-PM-001) and SSI-9973 (GAS-556-AC-PM-001) and associated consolidated conditions of approval derived from the impact assessment as listed in Table 8 Conditions of Approval requirements SWMP.

Table 8 - Conditions of Approval requirements SWMP

CoA	Description of Works	Refer to Section within This Plan
SSI 9471 - Port Kembla Gas Terminal Stage 3 Works		
Schedule3 Condition 1	Unless an environment protection licence authorises otherwise, the Proponent must comply with Section 120 of the POEO Act. Notes: > Section 120 of the POEO Act makes it an offence to pollute any waters. > The EPA has recommended the following limits for water pollutants should apply for the development: - an equivalent suspended sediment of no more than 50 mg/L above background turbidity levels during the construction stage. - No more than 20 ug/L of Total Residual Chlorine and a temperature of no less than 7o C below ambient water temperature for water discharges from the FSRU.	Section 5.3
Schedule 3 Condition 5	The Proponent must minimise any soil erosion associated with the construction of the development in accordance with the relevant requirements in the	Section 3.5 Section 4.4 Section 5.3

¹ This SWMP has considered the application of Best Practice Erosion and Sediment Control (IECA 2008) and the subsequent development of Appendix P, Pipeline Construction (IECA 2015) as being industry best practice ESC guidance for pipeline construction in providing improved outcomes for the environment.

CoA	Description of Works	Refer to Section within This Plan
	Managing Urban Stormwater: Soils and Construction (Landcom, 2004) manual, or its latest version.	Appendix C
Schedule 3 Condition 6	The Proponent must ensure that any construction activities in identified areas of acid sulphate soil risk are undertaken in accordance with Acid Sulfate Soil Manual (Acid Sulfate Soil Management Advisory Committee, 1998).	Section 5.3 Appendix D
Schedule 3 Condition 11	<p>Prior to the commencement of construction, the proponent must prepare a Spoil Management Plan to the satisfaction of the Planning Secretary and in consultation with the EPA, DPIE Water, NSW Ports, Port Authority of NSW and, an EPA accredited contaminated site auditor. The plan must be consistent with the Emplacement Cell Report and include:</p> <p>(a) a Contaminated Spoil Protocol that includes:</p> <ul style="list-style-type: none"> procedures for identifying and managing unexpected finds of contaminated or asbestos containing materials along the pipeline route and at Berth 101. a strategy for addressing any contamination that has been encountered, if required (including the remediation and/or removal of contaminated soil or groundwater); and details on how environmental and health risks will be mitigated and managed. 	<p>Section 4.3 Section 4.7 Section 5.3 Section 6 Appendix B Appendix D</p>
	<p>(b) a Dredge and Excavation Management Plan that:</p> <ul style="list-style-type: none"> includes an investigation of all reasonable and feasible measures to reduce the road haulage of spoil; describes all activities to be undertaken during dredging, excavation and disposal works; describes in detail the location and depth of disposal areas during all stages of construction, including the final form of the emplaced material; includes procedures for handling, transporting, storing and disposing of dredge and excavated material, including: <ul style="list-style-type: none"> • potentially acid forming material; • contaminated material; • asbestos containing materials; and <p>> includes a description of measures that would be implemented to:</p> <ul style="list-style-type: none"> • minimise the generation and dispersion of sediments during dredging and disposal; • minimise soil erosion and discharge of sediment and other pollutants to lands and/or Port Kembla harbour; • monitor and manage odours and air emissions during handling of sediments or from stored material prior to emplacement within the disposal area; and <p>> includes contingency measures in the event of a failure of the silt curtains; and</p>	<p>Section 4.3 Section 4.7 Section 5.3 Section 6 Appendix B Appendix D</p>
	<p>(c) a Water Quality Monitoring Plan that includes:</p> <ul style="list-style-type: none"> > a description of the water quality monitoring that would be undertaken to monitor turbidity and pollutant concentrations surrounding dredging and disposal works, including real-time turbidity monitoring; > a broader program to monitor harbour-wide water quality trends and the ecological health of Port Kembla Harbour; > objectives and performance criteria, including trigger levels for investigating any potential or actual adverse impacts associated with construction activities on water quality and the ecology of Port Kembla Harbour; > a plan to respond to any exceedances of the trigger levels and/or performance criteria, and minimise any adverse water quality impacts of the development; and > reporting procedures for the results of the monitoring program. 	<p>Section 6</p>

CoA	Description of Works	Refer to Section within This Plan
Schedule 3 Condition 12	The Proponent must implement the approved Spoil Management Plan for the development	Section 4.3 Section 5.3 Appendix B
Schedule 3 Condition 13	At the completion of any dredging, excavation and disposal works, the Proponent must engage a site auditor accredited by the EPA to issue a Section A Site Audit Statement confirming the suitability of the site for its intended use	Section 4.3 Section 4.6 Section 4.7 Appendix D
Schedule 3 Condition 17	The Proponent must ensure the development does not cause any direct or indirect impacts on heritage items located outside the approved development footprint.	Section 3.11 Section 4.8 Section 5.3 Appendix E
Schedule 3 Condition 18	Prior to commencement of construction, the Proponent must prepare an Unexpected Finds Protocol for managing heritage items identified during construction of the development, in consultation with BCD and the Illawarra Local Aboriginal Land Council, to the satisfaction of the Planning Secretary.	Section 4.8 Section 5.3 Appendix A Appendix E
Schedule 3 Condition 19	If human remains are discovered on site, then all work surrounding the area must cease, and the area must be secured. The Proponent must notify BCD as soon as possible following the discovery, and work must not recommence in the area until this is authorised by BCD	Section 4.8 Section 5.3 Appendix E
Schedule 3 Condition 20	The Proponent must ensure that no offensive odours are emitted from the development, as defined under the POEO Act.	Section 5.3
Schedule 3 Condition 31	The Proponent must minimise and/or prevent the: (a) dust emissions of the development, including wind-blown and traffic generated dust; (b) surface disturbance of the development; and (c) greenhouse gas emissions of the development.	Section 5.3
Schedule 3 Condition 32	The Proponent must ensure that air emissions from the development comply with the requirements of any EPL issued for the development.	Section 5.3
Schedule 3 Condition 36	The Proponent must: (a) minimise the waste generated by the development; (b) classify all waste generated on site in accordance with the Waste Classification Guidelines (NSW EPA 2014), or its latest version; (c) store and handle all waste generated on site in accordance with its classification; and (d) ensure all waste is disposed of off-site at appropriately licenced facilities	Section 5.3
Schedule 3 Condition 38	The Proponent must: (a) rehabilitate the site progressively, as soon as reasonably practicable following disturbance; (b) minimise the disturbance area at any time; and (c) employ interim rehabilitation strategies to minimise dust generation, soil erosion and weed incursion on parts of the site that cannot yet be permanently rehabilitated;	Section 5.3
SSI 9973 Modification 2 - Port Kembla Lateral Looping Pipeline		
A1	The Proponent must implement all reasonable and feasible measures to prevent, and if prevention is not reasonable or feasible, minimise any material harm to the environment that may result from the construction, operation, rehabilitation or decommissioning of the Port Kembla Lateral Looping Pipeline,	Section 5.3
A6	The Proponent must: rehabilitate the site corridor progressively, as soon as reasonably practicable following disturbance; minimise the disturbance area at any time; and employ interim rehabilitation strategies to minimise dust generation, soil erosion and weed incursion on parts of the site corridor that cannot yet be permanently rehabilitated.	Section 5.3

CoA	Description of Works	Refer to Section within This Plan
B8	The Proponent must minimise the dust generated during construction of the Port Kembla Lateral Looping Pipeline, including wind-blown and traffic generated dust.	Section 5.3
B9	The Proponent must; (a) ensure that construction, commissioning and operation of the Port Kembla Lateral Looping Pipeline does not cause any water pollution, as defined under section 120 of the POEO Act, including the management of surface water runoff, groundwater inflow into construction areas, and use of water for testing and commissioning of the pipeline;	Section 5.3 Appendix D Appendix F
	(b) minimise any soil erosion associated with the construction of the Port Kembla Lateral Looping Pipeline in accordance with the relevant requirements in the Managing Urban Stormwater: Soils and Construction (Landcom, 2004) manual, or its latest version;	Section 5.3 Appendix C
	(c) ensure that pipeline construction and installation is undertaken to minimise impacts on watercourses by applying management measures generally in accordance with the guidance series for Controlled Activities on Waterfront Land (DPIE Water 2012 or latest versions)and	Section 5.3 Appendix C
	(d) ensure that any construction activities in identified areas of acid sulfate soil risk are carried out in accordance with Acid Sulfate Soil Manual (Acid Sulfate Soil Management Advisory Committee, 1998) or its latest version.	Section 4.7 Section 5.3 Appendix G
B10	The Proponent must ensure the Port Kembla Lateral Looping Pipeline is constructed to minimise the potential for contaminant mobilisation	Section 4.7 Section 5.3 Appendix D
B11	An Unexpected Contaminated Land Finds Procedure must be prepared before the commencement of construction and must be followed should unexpected contaminated land (or suspected contaminated land) be excavated or otherwise discovered during construction. This Procedure must be included in the CEMP required by Condition C1	Section 4.7 Section 5.3 Appendix D
B13	The Proponent must ensure the construction of the Port Kembla Lateral Looping Pipeline does not cause any direct or indirect impacts on heritage items located outside the approved Port Kembla Lateral Looping Pipeline footprint.	Section 4.8 Section 5.3 Appendix E
B14	An Unexpected Heritage Finds and Human Remains Procedure must be prepared to manage unexpected heritage finds and human remains in accordance with guidelines and standards published by the Heritage Council of NSW or DPIE EES Group. This Procedure must be included in the CEMP required by Condition C1.	Section 4.8 Section 5.3 Appendix E
C1	Prior to commencing construction, the Applicant must prepare a Construction Environmental Management Plan (CEMP) for the Port Kembla Lateral Looping Pipeline to the satisfaction of the Secretary. This plan must:	Section 1.8 Appendix A
	a) be prepared in consultation with Council, Sydney Trains and TfNSW;	
	b) identify the statutory approvals that apply to the construction and commissioning of the Port Kembla Lateral Looping Pipeline;	Section 2.3
	c) describe the role, responsibility, authority and accountability of all key personnel involved in the environmental management of the Port Kembla Lateral Looping Pipeline;	Section 5.1
	d) describe the procedures that would be implemented to: <ul style="list-style-type: none"> • keep the local community and relevant agencies informed about the construction and commissioning of the Port Kembla Lateral Looping Pipeline; • receive, handle, respond to, and record complaints; • resolve any disputes that may arise; • respond to any non-compliance; and respond to emergencies; and	CEMP Section 2
e) include:	CEMP Part C	

CoA	Description of Works	Refer to Section within This Plan
	<ul style="list-style-type: none"> the following sub-plans: <ul style="list-style-type: none"> noise, including an out-of-hours work protocol; air quality; biodiversity; soil and water management; water management; traffic management; and waste a clear plan depicting monitoring to be carried out in relation to the Port Kembla Lateral Looping Pipeline 	
C2	The CEMP sub-plans must state how: (a) the mitigation measures identified in the Modification Report will be implemented; and (b) the relevant terms of this Schedule will be complied with.	CEMP This Plan Section 5.3
C5	The Proponent must implement the approved CEMP.	CEMP
C6	The Proponent must immediately notify the Department and any other relevant agencies immediately after it becomes aware of an incident. The notification must identify the development (including the development application number and name) and set out the location and nature of the incident.	Section 5.3
C7	Within seven days of becoming aware of a non-compliance, the Proponent must notify the Department of the non-compliance. The notification must set out the condition of this consent that the development is non-compliant with, why it does not comply and the reasons for the non-compliance (if known) and what actions have been, or will be, undertaken to address the non-compliance. Note: A non-compliance which has been notified as an incident does not need to also be notified as a non-compliance.	Section 5.3

2.4 Environmental Management Measures

Environmental Management Measures (EMM) derived from the Project Environmental Assessment relevant to this SWMP are listed in Table 9

Table 9 – Environmental Management Measure (EMM) requirements SWMP

EMM	Management Measure Category	Commitment	Refer to Section within This Plan
SSI 9471 – Port Kembla Gas Terminal Stage 3 Works			
C02	Contamination Berth 101	Removal of any remnant ACM fragments from the ground surface. The removal should be undertaken by a licenced removalist in accordance with relevant SafeWork NSW codes of practice. Following removal, a licenced asbestos assessor should inspect the site and provide a clearance certificate confirming removal of asbestos.	Section 5.3 Appendix D
C03	Contamination Berth 101	Inclusion of an unexpected finds protocol for contamination in the Construction Environmental Management Plan (CEMP) for the work associated with construction activities.	Section 5.3 Appendix D
C04	Berth 101; Proposed pipeline alignment; Dredging area	Preparation of an ASSMP by a consultant experienced in the identification and management of ASS. This will also include appropriate management and/or treatment of ASS. The ASSMP will be developed in line with the requirements of the Acid Sulphate Soils	Section 5.3 Appendix D Appendix G

EMM	Management Measure Category	Commitment	Refer to Section within This Plan
	and disposal area	Management Advisory Committee Guidelines (ASSMAC, August 1998 and as updated). The ASSMP will be prepared to identify, manage and treat the ASS encountered during excavation and dredging to minimise the production of acid leachate.	
C05	Proposed pipeline alignment	Preparation and implementation of a construction environmental management plan (CEMP) to include an unexpected finds protocol (UFP) to effectively manage the potential contamination issues identified from both a human health and environmental perspective. This would include the assessment of materials to be disturbed across the site to inform appropriate management strategies	Section 5.3 Appendix D
C06	Proposed pipeline alignment	Assessment and classification of all material to be disposed of offsite as per NSW EPA (2014) Waste Classification Guidelines, Part 1: Classifying Waste and Part 4: Acid Sulfate Soils prior to off-site disposal.	Section 5.3 Appendix D Appendix G
C07	Proposed pipeline alignment	If the proposed pipeline alignment is likely to intersect groundwater, assessment of groundwater quality in those sections should also be carried out to inform construction management of potential contamination issues.	Section 3.9 Section 5.3 Appendix D Appendix F Appendix G
W10	Water Quality	A site specific erosion and sediment control plan (ESCP) will be prepared as part of the CEMP to provide control of all land based excavation and stockpiling requirements. All erosion and sediment control measures shall be designed, implemented and maintained in accordance with 'Managing Urban Stormwater: Soil and Construction Volume 1' (Landcom 2004) ('the Blue Book).	Section 4.4 Section 5.3 Appendix C
W16	Water Management	A site specific emergency spill plan will be developed, and will include spill management measures in accordance relevant EPA guidelines. The plan will address measures to be implemented in the event of a spill, including initial response and containment, notification of emergency services and relevant authorities (including Roads and Maritime and EPA officers). An emergency spill kit will be kept on site at all times. All staff will be made aware of the location of the spill kit and trained in its use	Section 4.5 Section 5.3 CEMP, Appendix G (Section 9 Spill Management)
TB6	Sedimentation	A site specific erosion and sediment control plan will be prepared as part of the CEMP. All erosion and sediment control measures shall be designed, implemented and maintained in accordance with relevant sections of 'Managing Urban Stormwater: Soil and Construction Volume 1' (Landcom 2004) ('the Blue Book) (particularly section 2.2) and 'Managing Urban Stormwater: Soil and Construction Volume 2A – Installation of Services' (DECC 2008b). The	Section 4.4 Section 5.3 Appendix C

EMM	Management Measure Category	Commitment	Refer to Section within This Plan
		erosion and sediment control plan will include stockpiles, stormwater runoff, trees, site boundaries, site access and storage areas	
TB7	Sedimentation	Areas disturbed during the works will be rehabilitated, including stabilising disturbed soils to resist erosion and weed invasion via establishment of with a suitable turf species such as a native Couch or repaving roads and sealed surfaces. Stabilisation activities will be carried out progressively to limit the time disturbed areas are exposed to erosion processes Activities with a risk of soil erosion such as earthworks will not be undertaken immediately before or during high rainfall or wind events.	Section 4.4 Section 5.3 Appendix C
TB8	Water quality, chemical and fuel impacts on flora and fauna	A site specific emergency spill plan will be developed, and will include spill management measures in accordance relevant EPA guidelines. The plan will address measures to be implemented in the event of a spill, including initial response and containment, notification of emergency services and relevant authorities (including Roads and Maritime and EPA officers)	Section 4.5 Section 5.3 CEMP, Appendix G (Section 9 Spill Management)
TB9	Water quality, chemical and fuel impacts on flora and fauna	An emergency spill kit will be kept on site at all times. All staff will be made aware of the location of the spill kit and trained in its use	Section 5.3
TB10	Water quality, chemical and fuel impacts on flora and fauna	Any herbicides used for weed control will be applied to the manufacturer's specifications and as outlined in the manufacturer's Material Safety Data Sheet	Section 5.3
TB11	Water quality, chemical and fuel impacts on flora and fauna	Machinery will be checked daily to ensure there is no oil, fuel or other liquids leaking from the machinery. All staff will be appropriately trained through toolbox talks for the minimisation and management of accidental spills.	Section 5.3
H1	Unexpected Finds	The construction workforce would be given a heritage induction and supporting material to be able to identify materials of potential heritage value and how to respond.	Section 4.8 Section 5.3 Appendix E
H2	Unexpected Finds	A protocol to be followed in the event of an unexpected find would be developed and would include clear lines of communication and stop work procedures to be followed.	Section 4.8 Section 5.3 Appendix E
SSI 9973 Modification 2 – Port Kembla Lateral Looping Pipeline			
M01		Standard mitigation measures outlined in the approved EGP EIS (November,1996), along with mitigation measures per the APGA Code of Environmental Practice, will be implemented during construction and operation of the proposed modification.	Section 5.3
BDAR 05	Dust Management	Wet down areas to reduce dust generation during construction.	Section 5.3

EMM	Management Measure Category	Commitment	Refer to Section within This Plan
BDAR 06	ESC	Sedimentation and erosion control measures including silt fencing, sediment traps, etc. to prevent sediment-laden stormwater exiting the construction areas and to prevent scouring and erosion of land beyond the development footprint. All erosion and sediment control measures are to be constructed and installed in accordance with relevant guidelines, are to be regularly maintained for the duration of the construction period and are to be carefully removed at completion of works. – Implementation of temporary stormwater controls during construction and to ensure that discharges to the drainage channels are consistent with existing conditions.	Section 4.8 Section 5.3 Appendix E
ADD02	Unexpected Finds	Discovery of Unanticipated Aboriginal Objects All Aboriginal objects and Places are protected under the NPW Act. It is an offence to knowingly disturb an Aboriginal site without a consent permit issued by the EES. Should any Aboriginal objects be encountered during works associated with this proposal, works must cease in the vicinity and the find should not be moved until assessed by a qualified archaeologist. If the find is determined to be an Aboriginal object the archaeologist will provide further recommendations. These may include notifying the EES and Aboriginal stakeholders	Section 4.8 Section 5.3 Appendix E
ADD03	Unexpected Finds – Human Remains	Discovery of Aboriginal Ancestral Remains Aboriginal ancestral remains may be found in a variety of landscapes in NSW, including middens and sandy or soft sedimentary soils. If any suspected human remains are discovered during any activity you must: 1. Immediately cease all work at that location and not further move or disturb the remains. 2. Notify the NSW Police and EES' Environmental Line on 131 555 as soon as practicable and provide details of the remains and their location. 3. Not recommence work at that location unless authorised in writing by EES.	Section 4.8 Section 5.3 Appendix E

3 EXISTING ENVIRONMENT

3.1 Site Description and Existing Land use

As stated in Section 1.1 the pipeline will be constructed in three discrete segments:

- > Segment 1.1 – 4.3 km section from PKGT to Springhill Road.
- > Segment 1.2 – 2.2 km pipeline from Spring Hill Road to Five Islands Road , and
- > Segment 2 – 5.6 km pipeline from Five Islands Road to Kembla Grange Metering Station.

The zoned land use across the pipeline alignment includes special use and industrial use at Port Kembla and a mix of primarily residential and commercial uses at the surrounding localities. Major infrastructure in the region of Port Kembla includes the Princes Highway, which is a major state and regional highway connecting Sydney and Wollongong and regional areas further south. Princes Highway provides access to Port Kembla through turnoffs at Masters Road, Five Islands Road and Northcliffe Drive and is broadly utilised including by heavy vehicles from the port.

The South Coast railway line runs along the periphery of Port Kembla including the stations Port Kembla, Port Kembla North, Cringila and Kembla Grange. The rail line services commuters and is also used to transport bulk solid goods like coal, grain, copper, and steel from Port Kembla. The environmental features of Port Kembla and the surrounding region are limited given the extensive industrial, commercial, and residential development. Waterways in the region include the Gurungaty Waterway, Allans Creek, American Creek and Byarong Creek.

3.2 Soils and Landforms

Natural landforms along the pipeline alignment have been heavily altered by human activities. The Port area is generally a progressively reclaimed former coastal lagoon. Some residual natural slopes remain in the western extent of the alignment.

The pipeline alignment traverses a range of soil types predominantly alluvial soils being a silty and gravelly sandy soils in the east with increasing clay content in the western extents of the alignment. The soil landscape types expected during construction are:

- > Disturbed terrain (typically consisting of artificial fill)
- > Gwynneville (typically sandy loam overlying clay), and
- > Fairy meadow (typically sand overlying clay).

The soils are underlain by six geological units; Dapto Latite Member, Anthropogenic deposits, Illawarra Coal Measures, Broughton Formation, anthropogenic deposits – fill on Quaternary deposits, and Alluvial fan deposit.

Fill materials are expected to be intersected at various locations along the alignment, particularly in the Port area. Fill material generally contained coal, coal wash, slag with trace fragments of a range of anthropogenic materials including asbestos.

Soil texture and moisture content varies along the alignment with drier and finer texture soils being more prone to release causing erosion and nuisance dust. Other materials that will be present and susceptible to erosion may include imported bed and fill materials, imported road base and hardstand subgrade materials. These materials can form nuisance dust and be eroded when subjected to mechanical forces from construction equipment and removal of existing groundcover, such as pavements and vegetation.

3.2.1 Acid Sulfate Soils

Acid Sulfate Soils (ASS) are naturally occurring soils containing iron sulphides which on exposure to air, oxidise and create sulfuric acid. Disturbance of ASS and/or Potential Acid Sulfate Soils (PASS) can result in adverse impacts on surface and groundwater quality, flora and fauna and their habitats.

The project environmental assessment (EA) identified that ASS was found to occur in natural estuarine sediments particularly where dark grey and green clays are observed. Estuarine sediments exist within estuarine areas within the Port area (Segment 1.1) and are mapped as high probability of ASS.

Based on the proposed construction methodology, it is not expected that the relatively shallow depth of trenching associated with mainline pipeline construction will intercept marine sediments,

however the pipeline alignment may intercept these estuarine sediments during works associated with horizontal directional drilling (HDD) of Gurungaty Waterway (Segment 1.1) and Allans Creek (Segment 1.2).

Field investigations associated with the EA were undertaken consisting of subsurface investigations undertaken using a drill rig across a range of boreholes. The location of boreholes where investigations were undertaken is presented in Figure 2 below.

The results of field investigations are detailed in Appendix E of the EA (GHD 2018). Results of 15 samples taken from boreholes across Segment 1.1 and extracted from Appendix E are summarised below:

- > No samples reported pH-water less than 4.5
- > pH_{FOX} of less than 3.5 was reported for samples:
 - BH12 -12.25m-12.45m
 - BH12 – 13.5m-13.95m
 - BH17 – 7.5m

The field screening results indicate that there is a potential for actual ASS to be present at the locations and depths identified above however, boreholes and associated testing at Gurungaty Waterway (BH14 and BH15) and Allans Creek (BH23 and BH24) did not indicate the occurrence of ASS/PASS.

Given the proposed construction methodology and shallow depths of excavation it is unlikely that ASS will be encountered other than HDD works within Segment 1.1 and 1.2. There remains a risk of unexpected finds outside of HDD works.

Outside the Port area there were two areas within Segment 2 mapped as being Class 5 for acid sulfate soils, being:

- > Approximately 550 m extending west from Five Islands Road, and
- > The remaining 1.5km of the alignment at Kembla Grange.

Whilst Class 5 Acid sulfate soils do not typically contain acid sulfate soils, they are located within 500m of highly probable acid sulfate soils on adjacent lands and therefore present a risk of unexpected finds.

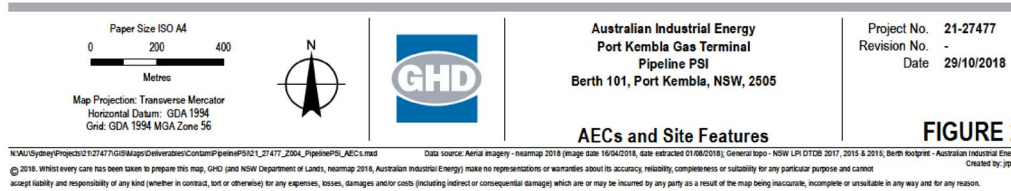
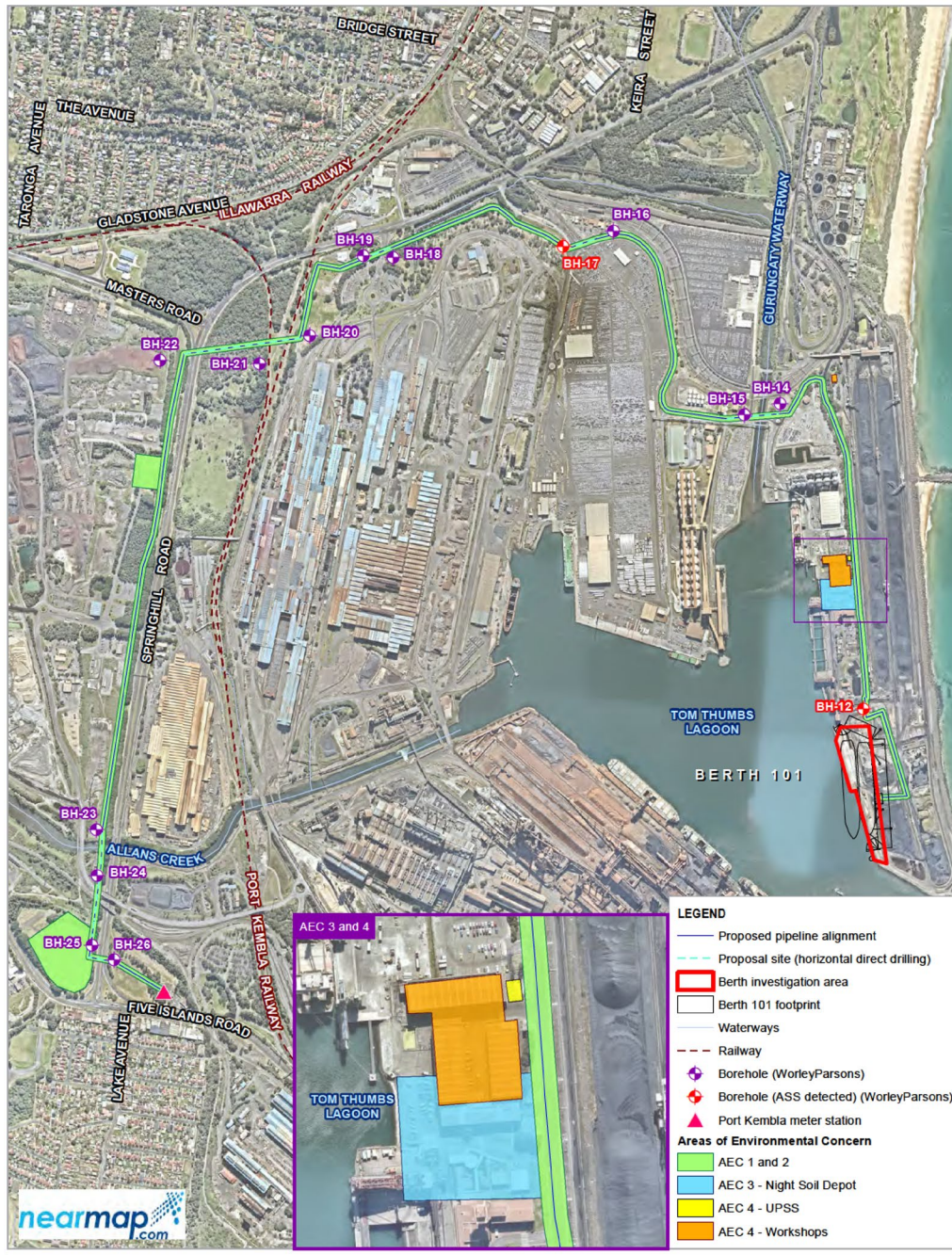

Figure 2 – Location of Boreholes to inform the EA (GHD 2018) – Source Appendix E Contamination Gas Pipeline

3.2.2 Contamination

A high-level assessment for contamination was undertaken during the EA for the Port area and determined that no widespread or gross contamination was found, however there is considered to be a moderate potential for contamination based upon the nature of the fill material and potentially

contaminating activities across the pipeline alignment associated with or resulting from surrounding industry.

The pipeline alignment through the Port area is within areas of highest concern. The project EA identified four areas of environmental concern (AEC) within the Port:

AEC 1 – Fill materials along the entire pipeline alignment including dredged materials, coal and coal by-product, steel production by-product (slag) and possible building demolition materials

- > AEC 2 – Spills and surface application of fuels along the entire pipeline alignment, oils and other chemicals associated with current and former industrial land uses
- > AEC 3 – Historical impacts associated with former nightsoil depot within PKCT, and
- > AEC 4 – Current and historical impacts associated with use of land adjacent to the alignment as workshops and fuel depots

Contamination assessment of the remaining works area outside the Port undertaken as part of the Geotechnical and Contamination Site Investigation Report (GAS-556-RP-GI-001) completed by Golder (2021) identified that spoil material generated from excavations is considered suitable for re-use onsite in areas of commercial and industrial land use as well as recreational and open space land use scenarios. Additionally, it was reported that whilst asbestos was not detected in soil sampling it was observed on the surface in bonded form at two of the investigation sites.

A waste classification assessment was also undertaken in accordance with the EPA *Waste Classification Guidelines* and determined that spoil from trenching not suitable for re-use was found to have an indicative waste classification of General Solid Waste (non-putrescible).

As with the Port area, the remaining works outside the Port are generally within land used by or in proximity of Port associated industries where there may be a risk of unexpected finds along the alignment being encountered. Potential sources of contamination (areas of environmental concern) were identified along the pipeline alignment outside of the Port being:

- > Fly-tipped waste (including suspected bonded and friable asbestos containing material)
- > Uncontrolled fill
- > An infilled drainage channel
- > Previously demolished buildings
- > Stockpiles of unknown origin, and
- > Groundwater at 243A Princes Highway, Unanderra.

3.3 Climate

The climate characteristics of the site are summarised below based on the Bureau of Meteorology (BOM) monitoring station located at Port Kembla (BOM No 068053). This is broadly representative of the project area.

Based on the available data, higher rainfall occurs in late summer months with lowest rainfall during autumn. This pattern also applies to the occurrence of 10mm and 25mm daily rain events. Temperatures are typically higher in summer months with wind conditions generally the same throughout the year with a pattern of higher wind speeds occurring in the afternoon.

3.4 Rainfall

Table 10 – Port Kembla Rainfall Data (mm)

	Jan	Feb	Mar	Apr	Mar	Jun	Jul	Aug	Sep	Oct	Nov	Dec
Mean	116.1	157.5	183.7	92.9	89.0	140.3	62.6	87.7	55.0	108.0	94.3	90.4
Low	19.0	5.4	15.8	13.7	1.1	0.0	0.0	5.9	4.1	8.1	12.4	10.8
High	350.9	575.0	528.5	350.3	420.7	465.1	220.1	286.1	188.6	423.6	600.3	366.0
Mean No of Days >=10mm	3.2	3.8	4.1	2.5	2.3	3.8	1.5	2.3	1.6	2.9	2.4	2.5
Mean No of Days >=25mm	1.6	1.6	1.9	1.1	1.0	1.6	0.5	1.1	0.5	1.2	0.9	0.9

Source http://www.bom.gov.au/climate/averages/tables/cw_068053_All.shtml

3.5 Rainfall Erosivity

The rainfall erosivity factor is a measure of the ability of rainfall to cause erosion (referred as “R” in the Revised Universal Soil Loss Equation RUSLE). The rainfall erosivity factor is used to determine the soil loss expected in tonnes per hectare over one year and is used in determining the erosion risk during the development of erosion and sediment controls.

The rainfall erosivity (R-factor) value derived from Best Practice Erosion Control (BPESC) Appendix E (IECA 2008) for Port Kembla and surrounds is presented in Table 11.

Table 11 – R- Factor and RUSLE Factor Assessment

RUSLE Parameter	Description	Adopted Value
R-Factor	Rainfall Erosivity	2,674 based on $R=164.74 (1.1177)^S S^{0.6444}$ Where S equals the 2yr – 6hr storm (11.1mm/hr as derived from BOM)
K – Factor	Soil erodibility factor	0.04 based on silty clay loam (characterised across the alignment)
LS Factor	Topographic Factor	1.0 (default due to variance across the alignment)
C-Factor	Ground Cover	1.0 (default based on cleared construction right of way CROW)
P-Factor	Soil Conservation	1.3 (default based on cleared CROW)

3.6 Temperature

Table 12 – Port Kembla Temperature Data (°C)

	Jan	Feb	Mar	Apr	Mar	Jun	Jul	Aug	Sep	Oct	Nov	Dec
Mean High	24.1	24.4	24.1	22.4	19.4	17.5	16.7	17.3	19.2	20.7	22.4	23.
Mean Low	18.4	18.7	18.0	15.7	12.7	10.9	9.8	10.3	11.8	13.7	15.3	17.1
Mean No of Days >=35	0.4	0.1	0.2	0	0	0	0	0	0.1	0.1	0.5	0.4

Source http://www.bom.gov.au/climate/averages/tables/cw_068053_All.shtml

3.7 Wind

Table 13 – Port Kembla Wind Data (km/h)

	Jan	Feb	Mar	Apr	Mar	Jun	Jul	Aug	Sep	Oct	Nov	Dec
Mean 9am	17.4	16.1	14.7	14.7	16.7	17.4	17.7	18.5	18.7	19.7	19.5	18.1
Mean 3pm	24.4	23.7	22.9	22.8	21.9	22.0	24.6	25.4	27.1	26.3	26.5	25.5

Source http://www.bom.gov.au/climate/averages/tables/cw_068053_All.shtml

3.8 Surface Water

Natural landforms along the pipeline alignment have been heavily altered by human activity. Residual natural slope remains in the western extent of the alignment with slopes generally draining to non-perennial drainage lines and minor water courses.

The eastern sections of the pipeline alignment generally drain south and / or east towards the nearest waterbody Allans Creek. The pipeline alignment crosses Allans Creek in the south and Gurungaty Waterway in the northeast. All parts of the alignment will ultimately drain into Inner Harbour (Tom Thumb Lagoon) through surface runoff, stormwater drainage systems.

Tom Thumb Lagoon, is a remnant saline coastal lagoon, has been progressively reclaimed by development of the Steelworks and Port Kembla harbour. The Lagoon was originally 500 hectares and now has an extent of 50 hectares.

Where ground surfaces have hardstand coverage surface water drainage is generally directed to public road stormwater systems. Sections of the pipeline alignment within the Port will drain to road stormwater systems that also include a number of settle ponds around the PKCT area.

Where no hardstand coverage exists, it is expected that surface water will penetrate ground surfaces along the CROW at a rate reflective of local soils. It is expected in high rainfall events, surface water will flow directly into the harbour or connecting tributaries via these formed stormwater systems and some overland flow.

3.9 Groundwater

The environmental and geotechnical assessment undertaken for the project identified that groundwater is inferred to be between 4.5 metres and 8.2 metres below ground level. Groundwater is expected to be tidally influenced in areas in close proximity to surface water bodies, with a general flow towards the nearest surface waterbody.

Typical trench excavation associated with the pipeline alignment is not expected to encounter groundwater as the depth of trenching is reasonably shallow, less than 2m, with the exception of trenchless crossings where deeper excavation is expected and groundwater may be encountered particularly deeper radius drilling to traverse the motorway, railway lines and waterways.

3.10 Flooding

The pipeline will be installed below ground across the full pipeline alignment and will be installed by trenchless methodology beneath both Gurungaty Waterway, Allans Creek, the Motorway existing roads and rail crossings. There will be no permanent changes to flow paths or flood storage due to the construction of the pipeline and no alteration in the potential for flooding of the waterways during flood events. Temporary impacts will be managed in accordance with the CEMP and Section 5.3 of this SWMP.

3.11 Heritage

3.11.1 Historical Heritage

During construction of the pipeline there is potential for historical features and archaeological deposits associated with early settlement and previous pastoral activities to survive in limited areas. Mapping and aerial photographs assessed during the EA indicate that the pipeline alignment traverses an area largely rural in nature, prior to industrialisation, with built features largely relating to homesteads and outbuildings. While built features appear to have largely been removed, historical features with the most likely potential to be present include:

- > remains of early private roads
- > house and outbuilding foundations
- > rural domestic rubbish dumps and associated archaeological deposits.

Subsequent investigation including ground penetrating radar during development of the pipeline alignment also identified potential for buried urns associated with the Wollongong Memorial Gardens to be in proximity to the pipeline alignment. There are no formal records or indicative surface markers to delineate their location.

Whilst the pipeline alignment has been developed to avoid known areas of heritage, there remains potential during excavation works to uncover heritage as unexpected finds.

3.11.2 Aboriginal cultural heritage

An extensive search of the Aboriginal Heritage Information Management System (AHIMS) was undertaken during the EA and identified one Aboriginal site within the assessment area, BSS-OS-1 (52-2-3618). 52-2-3618 is an open camp site recorded in 2008 and consists of two flaked stone artefacts likely to have been introduced with material used in road construction in an area of disturbance. The pipeline alignment has been developed to avoid this site.

The remaining areas of the alignment were assessed as being highly disturbed and having a low likelihood of archaeological potential due to the landforms, soil types and disturbance.

There remains however a potential risk for excavation works associated with the construction of the pipeline to expose unexpected archaeological finds including Aboriginal ancestral remains.

4 CONSTRUCTION ASPECTS AND IMPACTS

4.1 Construction Activities

The construction methodology for the works will generally involve but not be limited to:

- > Early access works comprising:
 - Environmental investigations, monitoring and works to prepare the site ahead of construction, and
 - Areas of work where access is available and approved prior to full site access dates.
- > Site survey and set out
- > Construction ROW preparation
 - Development and maintenance of project access points, tracks and roads
 - Location and non-destructive confirmation of all foreign services
 - Property management works to enable CROW access and construction

- Installation of temporary construction gateways where specified, and
- Clear and grade of the CROW as specified.
- > Transport of pipe to the CROW including stringing and bending operations
- > Trenching works
- > Trenchless crossing works
 - Horizontal directional drilling (HDD), and
 - Thrust bore.
- > Welding and Non-Destructive Testing (NDT)
- > Field joint coating works
- > Lowering in of pipe and backfill
- > Facility tie in works
- > Mainline valve works and tie ins
- > Cathodic Protection Works
- > Hydrostatic testing
- > Other pipeline works as specified:
 - Property Management Works
 - Permanent fencing and gateways
 - Watercourse rehabilitation
 - Trench breakers
 - Pipeline marker posts, and
 - Miscellaneous works required to satisfactorily complete the works.
- > Reinstatement and monitoring (including DLP).

Construction is expected to commence in October 2022 for a duration of approximately 11 months with practical completion forecast for September 2023. Refer to Contractors Program (GAS-599-SH-CN-001) for Execute Phase schedule.

4.2 Construction Soil and Water Impacts

The potential for impacts to soils and surface water related to pipeline construction would likely be temporary and of short duration. Key factors in the risk of impacts from pipeline construction includes:

- > Nature and duration of activities being undertaken
- > The size of the work area and extent of disturbance
- > Meteorological conditions, and
- > The adequacy of the mitigation measures applied to minimise impacts.

Pipeline construction will generally involve earthworks undertaken progressively in a linear fashion using a cleared CROW limited to approximately 20m in width. Clearing works will be undertaken by dozers, graders and excavators. Trenching works will generally be undertaken using excavators and for trenchless crossings the use of horizontal directional drilling.

The welded pipeline will be lowered into the trench and the trench backfilled using excavators to optimise the extent of open excavations. Progressive reinstatement of the disturbed areas will follow. On this basis the stockpiling of excavation and backfill materials will be of small volumes and relatively short durations. Exposed and stockpiled subsoils topsoils will also be temporary and of short duration.

Potential impacts attributable to pipeline construction include:

- > Topsoil removal and temporary stockpiling
- > Subsoil exposure and temporary stockpiling
- > Erosion and sedimentation
- > Mobilisation of sediments and pollutants
- > Spills and incidents
- > Exposure of ASS/PASS
- > Exposure of contaminants
- > Subsoil compaction, and
- > Decline in surface water quality

Mitigation measures to avoid or minimise impacts are outlined in Section 5.3. Additional management measures to reduce specific impacts are described below.

Cumulative impacts to soils and surface water are not anticipated as a result of pipeline construction. Where unexpected cumulative impacts are identified during works, they will be managed by measures outlined in Section 5.3, compliance with relevant CoAs, and coordination with external stakeholders including Third parties. The mechanism for identifying any potential unexpected cumulative impacts will be through monitoring, inspections, reporting and auditing.

4.3 Spoil Management

Spoil in the context of pipeline construction is defined as 'rock' or material 'other than rock' (OTR) resulting from pipeline excavation and trenchless activities. A Spoil Management Protocol has been developed and Attached as Appendix B. This protocol has been developed to manage spoil aspects and impacts limited to pipeline construction works specifically in accordance with SSI 9741 and SSI 9973. A Spoil Management Plan has been prepared and approved for Stage 2A and 2B works associated with SSI 9741, although not directly relevant, this plan has been considered and has informed the development of the protocol (Appendix B) as it relates to pipeline construction associated with Segment 1.1 (Stage 3 SSI 9741).

The protocol along with the mitigation measures described in Section 5.3 of this SWMP will address the following:

- > Spoil excavation, handling, storage, reuse and disposal
- > Processes and procedures that will be used for the management of classification of spoil, particularly those for fill material and contaminated and unsuitable material, and
- > Processes and procedures for the management of the environmental and community impacts of spoil transfer and reuse outside the site where and if applicable.

It is proposed to manage spoil generated from the works following the hierarchy of avoidance, minimisation, reuse, recycling and finally disposal.

4.4 Erosion and Sedimentation

Surface construction activities associated with pipeline construction have potential to result in erosion and sediment migration within the CROW, particularly:

- > Clearing of vegetation
- > Removal of hard stand and paved surfaces
- > Removal of topsoil and exposure of subsoils
- > Storage of uncompacted or unconsolidated topsoil and subsoil materials stored within construction boundaries, and
- > Migration of sediment on the CROW, access roads and public roads, from wheels of plant and equipment which have the potential to migrate during rainfall events.

Strategies to manage these risks are outlined in the Erosion and Sediment Control Plan Attached as Appendix C.

4.5 Spills and Incidents

During pipeline construction there is a risk of spills resulting from leakages, refuelling activities and mechanical failures of plant and equipment. Spills or leaks occurring within the CROW pose the risk the contamination of subsoil and mobilisation outside the CROW resulting in polluting downstream waterways (via stormwater network).

The risks to soil and surface water as a result of such incidents will be mitigated through the mitigation measures outlined in Section 5.3 of this SWMP and Section 4.8 and Appendix G (Section 9 Spill Management) of the CEMP. Incidents and environmental emergencies will be managed in accordance with Section 7 of the CEMP and where escalation is required the Project Emergency Response Plan (GAS-599-PA-HSE-008).

4.6 Pollution

In accordance with the Protection of the Environment Operations Act 1997 (POEO Act) the Environment Protection Authority (EPA) must be notified of pollution incidents that cause or threaten material harm to the environment.

‘Material harm to the environment’ includes on-site harm, as well as harm to the environment beyond the premises where the pollution incident occurred.

A ‘pollution incident’ includes a leak, spill or escape of a substance, or circumstances in which this is likely to occur. ‘Pollution incident’ is defined in the Dictionary to the Act as follows:

“Pollution incident means an incident or set of circumstances during or as a consequence of which there is or is likely to be a leak, spill or other escape or deposit of a substance, as a result of which pollution has occurred, is occurring or is likely to occur. It includes an incident or set of circumstances in which a substance has been placed or disposed of on premises, but it does not include an incident or set of circumstances involving only the emission of any noise.”

As the EPA is the appropriate regulatory authority (ARA), Jemena will notify EPA via the EPA Environment Line (telephone 131 555) in accordance with Part 5.7 of the POEO Act and will be managed through Jemena’s incident management procedure provided as Appendix H in the Jemena Environmental Management Plan (EMP) GAS-599-HSE-004.

4.7 Unexpected Contamination

In the event of unexpected discovery of contaminants including ASS during pipeline construction, works shall be suspended at the site of the discovery and the Unexpected Contaminated Lands Finds Procedure will be implemented. The Unexpected Contaminated Land Finds Procedure is attached as Appendix D.

4.8 Unexpected Heritage

In the event of unexpected discovery of heritage including human remains during pipeline construction, works shall be suspended at the site of discovery and the Unexpected Heritage Finds and Human Remains Procedure will be implemented. The Unexpected Heritage Finds and Human Remains Procedure is attached as Appendix E.

4.9 Water Sources

Water required as an input to construction activities will be potable and be sourced from commercially available local providers.

The project does not envisage the taking of water or use of water from a local source. Any requirement for taking water and subsequent use will be undertaken pursuant to the requirements of the Water Management Act 2000.

4.10 Dewatering and Water Reuse

Following rain events there may be a requirement for dewatering of excavations. Any dewatering will be undertaken in accordance with the dewatering and water reuse protocol (Appendix F).

4.11 Wastewater

Water that is surplus to construction needs or water that is encountered during works which cannot be reused on site or released in accordance with the POEO Act (i.e., it does not meet release criteria or cannot be treated in situ), will be transported by a licenced transporter to a licenced facility for disposal. All waste water will be managed in accordance with the Waste Management Plan (GAS-599-PA-EV-008).

5 CONSTRUCTION CONTROLS

5.1 Roles and Responsibilities

An Organisation Chart will be developed prior to the commencement of construction. Refer to Appendix A of Project Management Plan (GAS-599-PA-PM-015) for Organisation Chart for ECI Phase. Position descriptions describe the responsibilities specific to positions on the Project.

Table 14 below provides a summary of Nacap environmental management responsibilities for relevant roles.

Table 14 – Nacap Environmental Management Responsibilities

Role	Responsibilities
Project Director (Management Representative)	The Project Director provides environmental leadership and ensures that adequate, competent and experienced resources are provided and supported in the implementation of this SWMP.
Project Manager	> Provide support and guide in the implementation of this SWMP and associated controls

Role	Responsibilities
	<ul style="list-style-type: none"> > Provide management and leadership in the implementation of this SWMP > Ensure adequate resources are provided for implementing and maintaining environmental controls and mitigation measures in relation to air quality. > Take action including the stopping of work in response to natural events and activities which may impact on the environment or compromise the performance objectives, standards and commitments contained in this SWMP > Take action in the event of an environmental emergency and allocate the required resources to minimise environmental impact and harm.
Lands, Environment and Cultural Heritage (LECH) Manager	<ul style="list-style-type: none"> > Provide support and guide the implementation of this SWMP and associated controls > Provide environmental input and support to construction and associated methodologies > Support and guide site environmental incident investigation and reporting > Review internal and external project audits and coordinate the implementation of audit recommendations, and > Development, review and update of the SWMP as required.
Environment Advisor	<ul style="list-style-type: none"> > Provide and coordinate monitoring, inspections and audits of works > Provide and coordinate site-based training preparation and delivery > Routine record keeping and reporting in support of commitments in this SWMP > Reporting of hazards and incidents and implementing any rectification measures > Provide site based environmental incident investigation and reporting and corrective action management.
Project Supervisors	<ul style="list-style-type: none"> > Provide leadership for the implementation of commitments contained in this SWMP > Reporting of hazards and incidents and implementing any rectification measures.
Subcontractors	<ul style="list-style-type: none"> > Subcontractors engaged to perform works on behalf of Nacap will operate in accordance with all applicable legislation, Nacap procedures and this SWMP. > Subcontractors are required to report all incidents to their Nacap Supervisor immediately.
All Project Personnel and Visitors	<ul style="list-style-type: none"> > All Project personnel and visitors will uphold a general environmental duty to take all reasonable and practical measures to ensure that the activities on the whole site do not pollute the environment in a way which causes or may cause environmental harm.

5.2 Training and Awareness

All personnel and subcontractors working on site will undergo site induction including content relating to soil and water management. The induction will address elements related to soil and water management including:

- > Requirements of this Plan
- > Applicable and relevant legislative requirements
- > Roles and responsibilities for soil and water management

- > Typical construction activities that may impact soil and water management and associated environmental mitigation and management measures
- > Erosion and Sediment Control Plans
- > Spill management
- > Spoil management
- > Unexpected contamination finds
- > Unexpected heritage finds, and
- > Incident response procedures including emergency preparedness and response.

Targeted training undertaken as part of SWMS workshops, toolbox talks, or specific training will also be provided to personnel with a key role in soil and water management. Examples of training topics may include:

- > Construction Impacts to the environment and surrounding community
- > Planning and preparedness for weather events
- > Erosion and sediment controls installation and maintenance
- > Contamination
- > Heritage including human remains

5.3 Construction Soil and Water Management Measures

Table 15 – Construction Soil and Water Management Measures

No	Management Measure	Implementation	Responsibility
SW01	<p>All construction personnel and subcontractors are required to undertake a Project induction which will incorporate information on soils and water management specific to the project and field of operations and shall include the following:</p> <ul style="list-style-type: none"> > Environmental protection Legislation > Roles and Responsibilities for soil and water management > Information on the location of existing soils and water sensitivities > Information relating to the identification of soil contamination – such as by staining, odours, a marked / abrupt change in soil colour, soils with an oily feel or appearance, a slick / sheen on seepage or ponded water, buried waste products or other physical evidence, or patches of dead / stressed vegetation > The requirement to immediately report all soil contamination, both pre-existing soil contamination encountered during project activities and incidents resulting in project-generated soil contamination. > Mitigation management measures including erosion and sediment controls, storage of hydrocarbons and chemicals, waste and spill management > Protocols for responding to unexpected finds of contamination > Protocols for responding to unexpected finds of heritage and human remains > Incident reporting and record keeping. <p>A register attendance at all inductions will be maintained.</p>	Pre-Construction	Principal Contractor/ Subcontractors
SW02	<p>All construction personnel and subcontractors will participate in Safe Work Method Statement (SWMS) development that will include specific management measures relating to management of soil and water during construction.</p>	Pre-Construction	Principal Contractor/ Subcontractors
SW03	<p>In the event there are changes to people/plant/process or environment after the development of SWMS, ensure that any changes are communicated to work personnel including environmental hazards and controls which shall be recorded in a revised SWMS or SWMS review card and signed off by all involved in the activity.</p>	Per Event	Principal Contractor/ Subcontractors

No	Management Measure	Implementation	Responsibility
SW04	Weather conditions will be monitored / reviewed at the start of each day to enable construction activities or methods to be modified in response to wind / storm conditions predicted to generate soil and water impacts to the site as a result of construction activities. Monitor weather via the onsite meteorological monitoring station established for Stage 2A works. Weather information will also be obtained from the Bureau of Meteorology to measure atmospheric conditions and rainfall events in the locality of the Project within the previous 24-hour period and provide real time data on wind speeds within the locality.	Daily	Principal Contractor
SW05	Prior to first entry onto the Project site, all vehicles, plant and equipment must be checked for cleanliness and declared weed free before release by an authorised Project representative.	Construction	Principal Contractor/ Subcontractors
SW06	Appropriate use of Project access tracks, roads and works areas will involve: <ul style="list-style-type: none"> > Authorised Project vehicles entering the site only, there is no access to private vehicles within the Project area > All vehicles delivering materials, plant and equipment shall be registered and are required to maintain appropriate emission controls > Construction traffic shall travel at safe speeds as sign posted, and > Speed limits may be reduced in dusty conditions. 	Construction	Principal Contractor/ Subcontractors
SW07	Prepare environmental control plans (ECPs) based on the EA assessment that delineate the site, access points and environmental sensitivities including areas of confirmed ASS/PASS and contamination risk. ECPs will be communicated to all personnel via Pre-commencement Form 2, Pre-starts, toolboxes and site specific and activity specific awareness sessions.	Construction	Principal Contractor/ Subcontractors
SW08	Undertake all works generally in accordance with the project specification, CEMP and APGA Code of Environmental Practice.	Construction	Principal Contractor/ Subcontractors
SW09	Except as may be provided by the Project EPL 21529 (Stages 1, 2A and 2B), works shall be undertaken to comply with Section 120 of the POEO Act, which prohibits the pollution of waters.	Construction	Principal Contractor/ Subcontractors
SW10	The approved works area will be delineated and established in accordance with the Project survey and ECP. Use fencing and flagging where appropriate to establish No-Go zones and work limits. Ensure suitable areas within the CROW are identified to allow for contingency management of unexpected waste materials, including contaminated materials. Suitable areas will be required to include secondary containment and ESC to prevent migration of materials	Construction	Principal Contractor
SW11	Disturb soils only to the extent required in the Project specification	Construction	Principal Contractor/ Subcontractors
SW12	Minimise disturbance of watercourses as much as practicable and safe to do so. Ensure watercourse crossing works are undertaken generally in accordance with the guidance series for Controlled Activities on Waterfront Land (DPIE Water 2012 – or latest versions) Refer to: https://water.dpie.nsw.gov.au/licensing-and-trade/approvals/controlled-activity-approvals/what/guidelines	Construction	Principal Contractor/Sub contractors
SW13	Weather forecasts will be checked prior to commencing works and assess the need to reschedule or adjust works if there is the likelihood of significant rainfall or water flows.	Construction	Principal Contractor/ Subcontractors
SW14	Minimise the period in which the CROW is left exposed through works scheduling and plan to ensure disturbed areas are rehabilitated as soon as practicable.	Construction	Principal Contractor/ Subcontractors
SW15	Develop and implement erosion and sediment controls progressively ahead of construction. ESCs will be developed based on BPESC Appendix P Pipeline Construction (IECA 2015) and in accordance with the ESCP – Appendix C	Construction	Principal Contractor/ Subcontractors
SW16	Risk assess and install ESC controls to divert clean water around stockpiles and to contain, control and enable the treatment of run off from being released from works areas.	Construction	Principal Contractor
SW17	Surface water will be diverted around excavations and stockpiles and sites of chemical and hazardous material storage. All surface flow diversion, stockpile containment structures and other drainage protection measure will be regularly inspected, at least weekly and following rain events where runoff occurs (where accessible and safe to do so) and maintained in an effective condition. Drainage lines are not to be blocked / impeded by stockpiles or excavation works	Construction	Principal Contractor/ Subcontractors

No	Management Measure	Implementation	Responsibility
SW18	<p>Topsoil and subsoils will:</p> <ul style="list-style-type: none"> > be stripped to the minimum depth required for the performance of the works > be stockpiled separately > not be stockpiled against fence lines or trees or in proximity to mapped environmental sensitivities or existing habitat structures > not be driven over when stockpiled or used for the construction of erosion and sediment measures, and > be located away from areas of weed infestation <p>Report substantial loss of topsoil or damage to stockpiles for investigation and corrective action.</p>	Construction	Principal Contractor/ Subcontractors
SW19	Keep topsoil stockpiles < 2m high to minimise wind erosion. Compact as required to stabilise.	Construction	Principal Contractor/ Subcontractors
SW20	All spoil stockpiles will be located away from drainage lines, natural waterways, road surfaces and trees. Stockpiles will be protected against erosion and sedimentation Refer to Spoil Management Protocol Appendix B. Refer to Erosion and Sediment Control Plan Appendix C.	Construction	Principal Contractor/ Subcontractors
SW21	Provide adequate separation considerate of the height of stockpiles between vegetation, topsoil, and subsoil stockpiles to avoid mixing and inversion during works.	Construction	Principal Contractor/ Subcontractors
SW22	Appropriate gaps / breaks in stockpiled vegetation, topsoil and subsoil will be maintained. The gaps will provide a path for drainage to prevent the accumulation of surface water and flooding, enable installation of diversion measures such as inverts, berms and discharge features and provide a passage for fauna movement.	Construction	Principal Contractor/ Subcontractors
SW23	Implement AQMP (GAS-599-PA-EV-005) management and control measures during construction activities to minimise dust. At any time during visual and instrument monitoring of dust that approved emission levels are exceeded, temporarily modify or suspend dust generating activities until conditions subside.	Construction	Principal Contractor/ Subcontractors
SW24	If dust levels cannot be contained works must be modified or stopped until dust hazard is reduced to a manageable level, such that it can be controlled using the standard measures.	Construction	Principal Contractor/ Subcontractors
SW25	Apply ameliorants in accordance with the specification and any remediation works plan applicable to Segment 1.1.	Construction	Principal Contractor/ Subcontractors
SW26	Backfill the trench in accordance with the specification.	Construction	Principal Contractor/ Subcontractors
SW27	Install trenchbreakers in accordance with the specification.	Construction	Principal Contractor/ Subcontractors
W28	Machinery will be checked daily to ensure there is no oil, fuel or other liquids leaking from the machinery. All staff will be appropriately trained through toolbox talks for the minimisation and management of accidental spills.	Construction	Principal Contractor/ Subcontractors
SW29	<p>Respond to spills immediately.</p> <p>The priorities during spill response at all times are to:</p> <ul style="list-style-type: none"> > Protect human health and safety; > Protect the environment from harm; and > Consider commercial resources. <p>Specific priorities for environmental protection are to:</p> <ul style="list-style-type: none"> > Protect surface water and groundwater resources; > Protect soils; and > Protect habitat if present. <p>Report all spill events</p>	Construction	Principal Contractor/ Subcontractors
SW30	A spill is a release of any fuel, oil, grease or other chemical substance (liquid or powder) to the environment. Spill kits will be provided and maintained in immediate proximity of hard stand work areas and stores. Vehicle spill kits will be carried on fuel trucks and vehicles (and / or plant) working near major plant and equipment. Relevant personnel will be trained in the use of spill kits	Construction	Principal Contractor/ Subcontractors
SW31	Refer to the Code Safe Video located on the Nacap Portal for instruction on Spill Response http://portal.nacap.com.au	Construction	Principal Contractor/ Subcontractors
SW32	<p>Spill management includes the following actions:</p> <ul style="list-style-type: none"> > Halt the continued release of the substance being spilled to minimise the spill volume > Halt, contain and clean up and remediate the spill site using appropriate PPE > Contain the spill if safe to do so to as small an area as possible > Containment methods shall include use of absorbent materials, earth bunds, sandbag bunds, temporary sumps and drain inlet blocks 	Construction	Principal Contractor/ Subcontractors

No	Management Measure	Implementation	Responsibility
	<ul style="list-style-type: none"> > Every effort shall be made by on site personnel to contain the spill to the smallest area possible to limit the extent of contamination, with priority being to ensure health and safety hazards and sensitive environments are avoided. Every effort will be made to avoid spills entering the surface and ground water systems > In the event of a spill, the individual/s responsible for its detection shall notify the Supervisor as soon as reasonably practicable > If the spill is beyond the capacity of the immediate project resources follow the Emergency Response Plan (ERP) > Clean up and restoration methods will vary according to the extent and nature of the spill and the nature of the environment in which the spill occurred. In most cases, the appropriate action will be the removal of contaminated materials from the site for disposal at an appropriately licensed facility, and > Ensure waste tracking records are kept where required 		
SW33	Report improper storage or leaks and spills, including location, size, and nature of spill, and details of clean-up/ remediation for investigation and corrective action; report substantial spills or pollution incidents to the EPA hotline 131 555 as per Sect 7.2 of the CEMP	Construction	Principal Contractor/ Subcontractors
SW34	Environmental monitoring of significant spill sites will be undertaken to identify any potential impacts and evaluate the success of response and rehabilitation actions.	Construction	Principal Contractor
SW35	When dewatering is required following rain events, dewatering discharge points will preferentially be to vegetated areas adjacent to excavations. Discharge scour protection or flow dissipation measures will be installed at the release site.	Construction	Principal Contractor/ Subcontractors
SW36	Dirty surface water retained within bunded structures on site is to be tested (and treated if required) before being released to ground or reused onsite in accordance with the Dewatering and Water Reuse Protocol (Appendix F) (e.g., for dust suppression).	Construction	Principal Contractor/ Subcontractors
SW37	For active watercourses (where water is flowing), suitable monitoring of water quality is to be conducted both upstream and downstream of construction site prior to, during, and post works to ensure compliance. A register is to be maintained reflecting these results and static test points.	Construction	Principal Contractor/ Subcontractors
SW38	Any stormwater released from site during dewatering events must meet the requirements outlined in the Dewatering and Water Reuse Protocol. <ul style="list-style-type: none"> > pH between 6.5 and 9.0 > Total Suspended Solids < 50mg/L > No visible oil, grease, or other contaminants 	Construction	Principal Contractor/ Subcontractors
SW39	When crews are dewatering, ensure: <ul style="list-style-type: none"> > Appropriate scour protection and filtration methods to be determined by Environmental representative based on site assessment > Refer to dewatering protocol (Appendix F). > Adhere to checklist and prompts when setting up for dewatering process. > Continually monitor process and water directions > Dewater to CROW drainage points. If unsuitable because of slope, then discharge locations to be risk assessed > Check waterbody for fauna prior to dewatering, and if fauna is present contact fauna spotter catcher for mitigation and relocation 	Construction	Principal Contractor/ Subcontractors
SW40	In the event of uncovering materials with a nuisance odour report the find to the Environmental advisor. Odorous material shall be managed in accordance with the Unexpected Contaminated Finds Procedure – Appendix C (GAS-599-PR-CN-001)	Per Event	Principal Contractor/ Subcontractors
SW41	In the event of uncovering contaminants including asbestos report the find to the Environmental advisor. Contaminants and asbestos shall be managed in accordance with the Unexpected Contaminated Finds Procedure Appendix C (GAS-599-PR-CN-001)	Per Event	Principal Contractor/ Subcontractors
SW42	At locations where there may be a risk of the presence of Acid Sulphate Soils (ASS) or Potential Acid Sulphate Soils (PASS), visual field assessment of soil conditions of undisturbed and disturbed soils will be undertaken. Field assessment will be guided by key identification characteristics (based on soil appearance/colouring, soil odour and the presentation of surrounding vegetation) and will be used to identify any potential need for further field assessment such as pH testing or further sampling and NATA laboratory testing to confirm the presence of ASS / PASS. For any ground disturbing activity where there is a potential to disturb ASS/PASS works will be undertaken in accordance with the Acid Sulfate Soils Management Plan (ASSMP) – Appendix G.	Construction	Principal Contractor/ Subcontractors
SW43	All instances of soil contamination will be recorded in the Incident Register – with accompanying location information, site plan (including the mapped extent of the contaminated area), photographs (if relevant), record of notification to Jemena, and action(s) taken. This will apply to both: <ul style="list-style-type: none"> > pre-existing soil contamination encountered during project activities, > instances of soil contamination resulting from project activities, and > Unexpected contamination finds. 	Construction	Principal Contractor/ Subcontractors

No	Management Measure	Implementation	Responsibility
SW44	<p>The following controls will be implemented when handling and stockpiling contaminated materials:</p> <ul style="list-style-type: none"> > PPE suitable for the subject contamination following risk assessment. PPE may include respiratory protective equipment, disposable coveralls, gloves and boot covers > Undertake a pre-start or site specific awareness for personnel required to work in contaminated areas, detailing risks of the contaminants, potential exposure pathways and management measures > Stockpiles will be segregated to avoid cross contamination > Stockpiles will be stabilised and where applicable protected by secondary containment and ESC to capture and control clean water diversions and runoff which will be collected and disposed appropriately > Stockpiles to be clearly identified with signs and communicated to work crews > All contaminated stockpiles to be covered with geotextile fabric or similar (where feasible); > Works will be programmed to limit stockpiling, > All materials to be tracked in the Materials Tracking Register > Ensure all handling and transport of contaminated spoil for offsite treatment/disposal is undertaken in accordance with the WMP (GAS-599-PA-EV-008) including assessment and classification of all material to be disposed of offsite as per NSW EPA (2014) Waste Classification Guidelines, Part 1: Classifying Waste and Part 4: Acid Sulfate Soils prior to off-site disposal > All waste transport offsite for disposal to be recorded in the Disposals Register > Ensure decontamination of all personnel, plant and equipment is undertaken in designated areas to prevent mobilisation of contaminants outside of controlled areas 	Construction	Principal Contractor/ Subcontractors
SW45	<p>In the event of uncovering suspected heritage artifacts including human remains report the find to the Environmental advisor. Heritage finds including human remains will be managed in accordance with the Unexpected Heritage Finds & Human Remains Procedure Appendix D (GAS-599-PR-CN-001)</p>	Per Event	Principal Contractor/ Subcontractors
SW46	<ul style="list-style-type: none"> > Undertake continuous monitoring of road ways, driveways and Potential internal sources. > Maintain good housekeeping at project access points and minimise mud and dirt accumulating or migrating from entrances and exits. > Deploy preventative measure in the form of rubber matting or aggregate. > If sediment tracking does reach roadways, the project will deploy road sweepers to removed sediment before rain or further tracking occurs. 	Construction	Principal Contractor/ Subcontractors
SW47	<p>Undertake progressive rehabilitation of the CROW:</p> <ul style="list-style-type: none"> > Excavations along the CROW and within waterways shall be reinstated as soon as practicable after installation of the pipeline and associated works > Amelioration of subsoils or topsoils to be undertaken as part of backfilling and/or CROW rehabilitation per project specifications, landowner line list and any remediation works plan applicable to Segment 1.1 > Undertake all property specific rehabilitation including soil amelioration, fertilising, and reseeding requirements in accordance with landowner line list and any other project access agreements and permits > Subsoils are to be returned to the base of the excavation, and the retained topsoil containing seed bank and vegetative propagules to be placed over the backfilled trench and CROW. > Prioritise stabilisation of the CROW through re-vegetation, use of stabilising binders and or geofabric / jute mesh / blankets. > Waterway crossings to be reinstated in accordance with specification and or waterway authority requirements. > Maintain temporary ESC and exclusion fencing (where required) until re-vegetation is suitably established and the CROW is stable. 	Construction	Principal Contractor/ Subcontractors
SW48	<p>Where remediation is required a Remediation Action Plan (RAP) will be prepared by a suitably qualified contaminated land consultant and be provided to the Project nominated site auditor for review. Following any remediation works undertaken as part of a RAP, a Section A Site Audit Statement/ Site Audit Report, will be prepared by a NSW EPA accredited Site Auditor to confirm that the contaminated land disturbed by the works has been made suitable for the intended land use.</p>	Construction	Principal Contractor
SW49	<p>Refer also to the following subplans</p> <ul style="list-style-type: none"> > Air Quality Management Plan (GAS-599-PA-EV-005) > Biodiversity Management Plan (GAS-599-PA-EV-006) > Traffic Management Plan (GAS-599-PA-CN-002), and > Waste Management Plan (GAS-599-PA-EV-008). <p>Implement the associated management measures as required</p>	Construction	Principal Contractor/ Subcontractors

No	Management Measure	Implementation	Responsibility
SW50	Incidents associated with soil and water management will be managed in accordance with Section 7 of the CEMP.	Per Event	Principal Contractor/ Subcontractors
SW51	Undertake monitoring of works in accordance with Section 6 of this SWMP.	Construction	Principal Contractor
SW52	Chemical applications to land, water, or vegetation such as herbicides, disinfectants flocculants or erosions control polymers will be applied and controls in accordance with manufacture specifications, SDS directions, and known site-specific contains.	Per event	Principal Contractor/ Subcontractors
SW53	<p>Undertake all biosecurity, weed, pest and pathogen management in accordance with the Weed and Pest Management Procedure (GAS-599-PR-EV-001)</p> <p>A clean-down should remove all soil, pathogen and vegetative material from a project vehicle or machinery:</p> <ul style="list-style-type: none"> > Clean downs will be undertaken at an appropriate facility prior to access to the project area > All exposed areas of the vehicle/plant item are to be cleaned from bumper to bumper using compressed air, vacuum, brush, or high-pressure water spray > Pathogen treatment may require disinfectant > Key areas for attention include radiators, walking gear, belly plates, mudguards, cabins, wheels, sump guards, suspension, engine bays, trays, winches and toolboxes > Ensure attention is paid to the carpets, floor mats and seats within the cabin > The driver/operator is obliged to take all necessary steps to ensure that no contaminants are attached to clothing including boots, and > Additional cleaning measures may be required as directed by the LECH Manager or delegate to satisfy weed hygiene requirements 	Construction	Principal Contractor/ Subcontractors

6 MONITORING AND INSPECTIONS

The Nacap LECH Manager or delegate shall coordinate inspections and monitoring of works during construction activities and be available to provide advice and direction on the adequacy and requirement for environmental control measures throughout construction; check and record compliances with works procedures and this SWMP.

Inspections and monitoring specific to identifying potential soil and water issues will include but not be limited to:

- > The effectiveness of topsoil and subsoil stockpiling and management
- > Effectiveness of erosion and sediment control protection measures namely:
 - > conveyance of diversion waters
 - > site drainage
 - > protection of high risk areas, and
 - > integrity and maintenance of erosion and sediment controls.
- > Any erosion or sediment discharge events
- > The identification and management of any soil contamination locations
- > Testing and categorisation of surplus spoil targeted for offsite reuse or disposal
- > The identification and management of PASS/AASS
- > Exclusion zones
- > In advance of forecast rain events and at the conclusion of ensuing rain the active construction works areas, access routes and associated work areas will be assessed to ensure the effectiveness of erosion and sediment control protection measures
- > Baseline water quality monitoring in relation to watercourse crossings
- > Water quality monitoring for reuse and or release in relation to dewatering
- > Remediation/clean up response
- > Inspecting adequacy and management of any flow diversion measures
- > Monitoring flow and sedimentation of drainage lines
- > Visual assessment of standing surface water quality
- > Monitoring of wash pits where utilised for the works
- > Inspection of water usage and maintenance of water savings measures, and
- > Inspection of availability, use and effectiveness of spill kits.

Site inspections will be recorded (along with actions and issues observed) and actioned appropriately within agreed timeframes. Inspections will be recorded as part of Environmental Inspection Checklist. Additional requirements and responsibilities in relation to inspections are documented in Section 8 of the CEMP.

7 RECORD KEEPING AND REPORTING

7.1 Record Keeping

The Project shall maintain a documentation and record system in support of this SWMP and monthly Project HSE reporting requirements to enable review and auditing of environmental management systems and procedures.

The following records are expected to be generated in relation to soil and water management and monitoring:

- > Visual monitoring and environmental inspection records
- > Stakeholder discussion records
- > Induction, training and awareness records
- > Site and construction activity specific records and registers
- > Waste management records
- > Disposal Register
- > Materials Tracking Register
- > Soil Test Lab Results
- > Water Test Lab Results
- > Disturbance records
- > ESCPs
- > Erosion & Sediment Control (ESC) installation registers
- > Water use records and register
- > Dewatering register
- > Reporting of Environmental Incident, non-conformances and corrective actions
- > Audit reports, and
- > Complaints.

7.2 Reporting

Daily, Weekly, Monthly and Annual Reporting will include information on relevant environmental data and commentary as generated in support of incident and complaint management, regulatory and contractual requirements.

7.2.1 Environmental Incident Reporting

Environmental incidents will be reported in accordance with the CEMP Section 7.1.

7.2.2 POEO Act Incident Notification

In accordance with the Protection of the Environment Operations Act 1997 (POEO Act) the Environment Protection Authority (EPA) must be notified of pollution incidents that cause or threaten material harm to the environment. POEO Act reporting will be undertaken in accordance with the CEMP Section 7.2.

8 REVIEW AND IMPROVEMENT

Section 8.6 and 8.7 of the CEMP describes the process for the review and continual improvement of project documents including this SWMP.

Continual improvement of this SWMP will be achieved by ongoing evaluation of environmental management performance against environmental policies, objectives and targets, for the purpose of identifying opportunities for improvement.

The continual improvement process is designed to:

- > Identification of opportunities for improvement of environmental management and performance
- > Identification through incident investigation the cause or causes of non-conformance,
- > Development of corrective and preventative measures to address non-conformance and process deficiency
- > Assessment of the effectiveness of corrective actions
- > Documentation and communication of change and process improvements, and
- > Any updates to the SWMP as described above.

A copy of any updated plan and changes will be distributed to all relevant stakeholders and regulatory authorities. Any changes to work practices arising from document review will be communicated via pre-start alerts, toolboxes, SWMS review and or site specific awareness sessions.

APPENDIXA CONSULTATION RECORD

The following table provides a detailed record of the consultation activities associated with this Plan.

Stakeholder	Date Sent	Send Method	Due Date	Date Received	Comments
Wollongong City Council (WCC)	30/08/2022	Email	13/09/2022	10/11/2022	Completing review, however, note that the deadline has passed.
Sydney Trains	30/08/2022	Email	13/09/2022	15/09/2022	No Comments
Transport for NSW	30/08/2022	Email	13/09/2022	21/09/2022	No Comments
NSW Ports	25/08/2022	Email	9/09/2022	No Response	No Comments
Port Authority NSW	25/08/2022	Email	9/09/2022	7/09/2022	No Comments
DPI Fisheries	25/08/2022	Email	9/09/2022	2/09/2022	No Comments
Enviro IA	26/08/2022	Email	9/09/2022	8/09/2022	Comments provided and updated into document
EPA	25/08/2022	Email	9/09/2022	30/08/2022	Comments provided and updated into document

APPENDIXB SPOIL MANAGEMENT PROTOCOL

SPOIL MANAGEMENT PROTOCOL	
Purpose	This Spoil Management Protocol supports the purpose and objectives outlined in the Construction Environmental Management Plan CEMP (GAS-599-PA-EV-001), Soil and Water Management Plan SWMP (GAS-599-PA-EV-0070) and Waste Management Plan WMP (GAS-599-PA-EV-008) and are applicable for project based construction activities to ensure that all reasonable and practical measures are undertaken to ensure that the activities across all works do not pollute the environment in a way which causes or may cause environmental harm.
Scope	This protocol is to be applied to all pipeline construction works (SSI 9741 Stage 3 & SSI 9973 Stage 1). The term spoil does not refer or include topsoil.
Legislative Requirements	<p>Protection of the Environment Operations Act 1997 (NSW) (POEO Act)</p> <p>The POEO Act covers the requirements for waste generators in terms of storage and correct disposal of waste and establishes the waste generator as having responsibility for the correct management of waste, including final disposal.</p> <p>Protection of the Environment Operations (General) Regulation 2009</p> <p>The Regulation contains provisions relating to:</p> <ul style="list-style-type: none"> > environment protection licences, > the issuing of penalty notices under the Act and certain related environmental legislation, > the appropriate regulatory authority for certain type of activities, > notification of pollution incidents. <p>Protection of the Environment Operations (Waste) Regulation 2014</p> <p>Makes requirements relating to non-licenced waste activities and non-licenced waste transporting, for example the way in which waste must be stored or transported, reporting and record-keeping requirements. The regulation exempts certain waste streams from the full waste tracking and recordkeeping requirements and allows the EPA to approve the immobilisation of contaminants in waste.</p> <p>Waste Avoidance and Resource Recovery Act 2001</p> <p>The objective of the Act is to encourage the most efficient use of resources, to reduce environmental harm, and to provide for the continual reduction in waste generation in line with the principles of ecologically sustainable development (ESD). The following hierarchy for managing waste, from most desirable to least desirable, meets the objects of the Act:</p> <ul style="list-style-type: none"> > Avoid unnecessary resource consumption > Recover resources (including reuse, reprocessing, recycling and energy recovery), and > Dispose (as a last resort).
Guidelines	<ul style="list-style-type: none"> > <i>National Environment Protection (Assessment of Site Contamination) Measure 1999</i> > <i>NSW EPA (2014a). Waste Classification Guidelines Part 1: Classification of Waste (NSW EPA, 2014)</i> > <i>NSW EPA (2014b). Waste Classification Guidelines Part 4: Acid sulfatc soils (NSW EPA, 2014)</i> > <i>NSW EPA Sampling Design Guidelines (NSW EPA 2022)</i> > <i>Acid Sulfate Soils Manual (Acid Sulfate Soil Management Advisory Committee 1998)</i>
Protocol and Mitigation	<p>Spoil Management</p> <p>Spoil in the context of this protocol and this SWMP is defined as 'rock' or material 'other than rock' (OTR) resulting from pipeline excavation and trenchless activities. This protocol and SWMP will address the following:</p> <ul style="list-style-type: none"> > <i>Spoil excavation, handling, storage reuse and disposal</i> > <i>Processes and procedures that will be used for the management of classification of spoil, particularly those for fill material and contaminated and unsuitable material, and</i> > <i>Processes and procedures for the management of the environmental and community impacts of spoil transfer and reuse outside the site where and if applicable.</i> <p>It is proposed to manage spoil generated from the works following the hierarchy of avoidance, minimisation, reuse, recycling and disposal.</p> <p>Spoil Management Hierarchy</p> <p>Based on the expected soil hazard and waste categorisation outlined in the Environmental Assessment (EA) and SWMP, Project spoil shall be managed generally in accordance with the hierarchy presented in Table 1 below.</p> <p><i>Table 1 Spoil Management Hierarchy</i></p>

Rank	Options	Response	Application
1	Avoid and reduce spoil generation	Reduce the amount of spoil being generated through design (realignment) and construction methodology (ie trenchless).	Pre-construction
2	Reuse within the Project	Reuse as trench backfill	Construction
3	Reuse for environmental works	Reuse for ESC structures	Construction Reinstatement
4	Reuse for land restoration	Reuse for reinstatement and site remediation	Reinstatement
5	Disposal offsite as waste	Disposal of excess spoil as waste at an approved facility licenced to receive the material.	Potential but not preferred

Spoil Materials

Site assessment undertaken in the development of the EA has identified the following expected spoil materials and expected management as outlined in the CEMP, SWMP and WMP:

- > Topsoil
 - o To be stockpiled and reused during reinstatement
- > Subsoil being 'rock' and material 'other than rock' that has been characterised as being suitable for reuse based on the previous assessment and visual observations.
 - o Stockpile and reuse as trench/excavation backfill.
 - o Stockpile and reuse on site for land restoration
 - o Stockpile and transport off site for reuse, and
 - o Manage drilling muds for reuse in accordance with EPA Resource Recovery Orders and the Waste Classification Guidelines Part 1: Classification of Waste
- > Materials that are determined to be unsuitable for reuse or are discovered and managed in accordance with the Unexpected Contaminated Land Finds Protocol (Appendix D) will be:
 - o Stockpiled separately to all other materials, delineated, and managed to ensure that ESC measures are applied to restrict contact with clean water diversions and prevent movement of material from designated stockpile locations.
 - o Materials suspected or proven to be contaminated will to be managed in accordance with the Unexpected Contaminated Lands Find Procedure – Appendix D.
 - o At the guidance of a suitably qualified land contamination consultant be subject to sampling and laboratory analysis of materials in accordance with relevant guidelines including but not limited to the NSW EPA Sampling Design Guidelines 2022 to determine suitability for reuse onsite or offsite in accordance with EPA Resource Recovery Orders or otherwise classified in accordance with the EPA Waste Classification Guidelines disposal, and
 - o Transport offsite for disposal (where required) including completing any applicable Waste Tracking records, ensuring that transporters and receivers are registered and or licensed with EPA.

Environmental Mitigation Measures

Environmental Mitigation Measures relating to the management of spoil are presented in Section 4.3 and 5.3 of the SWMP and Section 3 and Section 4.3 of the Waste Management Plan (WMP) GAS-599-PA-EV-008.

Relevant Authority	EPA 131 555 The Environment Line handles general inquiries about environmental issues and takes reports of pollution for which the EPA has regulatory responsibilities. Environment Line is a one-stop pollution and environmental incident reporting service provided by Environment and Heritage Group (EEG) and EPA.
---------------------------	----------------------------------------------------------------------------------------------------------------------------------------------------------------------------------------------------------------------------------------------------------------------------------------------------------------------------

APPENDIX C EROSION AND SEDIMENT CONTROL PLAN

Jemena

Port Kembla Pipeline Project

EROSION AND SEDIMENT CONTROL PLAN

Document No.: GAS-599-PA-EV-003 | Revision 2

2	Issued for Use	BRO	RPO	BPH	JHE	1-DEC-2022
1	Issued For Use	BRO	RPO	BPH	JHE	18-NOV-2022
0	Issued for Use	BRO	ZFR	NFU	JHE	31-MAY-2022
A	Issued for Review	BRO	BPH	NFU	JHE	5-MAY-2022
Rev	Description	By	Checked	QA	Nacap Approved	Date

REVISION HISTORY

This table describes changes made for numerical revisions after Rev 0

Date	Rev	By	Description
17/11/2022	1	BRO	Updated in response to AIE Review

CONTENTS

ACRONYMS	6
GLOSSARY	7
1 INTRODUCTION	9
1.1 Purpose and Scope	9
1.2 References	9
1.3 Principal Contractor Details.....	10
1.4 Environmental Management System Overview.....	10
2 ENVIRONMENTAL PLANNING AND GOVERNANCE	10
3 EXISTING ENVIRONMENT	10
4 EROSION AND SEDIMENT CONTROL MANAGEMENT	10
4.1 Guidelines and Best Practices.....	10
4.2 Roles and Responsibilities	11
4.3 Erosion and Sediment Management Objectives	12
4.4 Erosion Hazard Risk	12
4.4.1 Erosion Hazard Risk Assessment.....	12
4.4.2 Erosion Hazard Risk - Topography	13
4.4.3 Erosion Hazard Risk – Rainfall	13
4.4.4 Erosion Hazard Risk – Estimated Soil Loss	13
4.4.5 Overall Erosion Hazard Risk	13
4.5 Erosion and Sediment Control Design Standards.....	14
4.6 Erosion and Sediment Control Process	14
4.6.1 Level 1 - Erosion and sediment controls:.....	14
4.7 Erosion Sediment Control Measures.....	16
4.8 Standard ESC Installations - Level 1 Erosion Hazard Risk	17
4.9 Berm Spacing.....	18
4.10 Drainage Control Standards	18
4.11 Waterway Crossings within Level 1 Erosion Hazard Risk Areas	19
4.12 Responding to Adverse or Forecast Weather Conditions	20
4.13 Rehabilitation	20
5 MONITORING AND INSPECTIONS	20
6 RECORD KEEPING AND REPORTING	21
6.1 Record Keeping.....	21
6.2 Reporting	22
7 REVIEW AND IMPROVEMENT	22
ATTACHMENT 1 TYPICAL CROW LAYOUTS	24
ATTACHMENT 2 STANDARD ESC INSTALLATIONS	26

LIST OF TABLES

Table 1 – Emergency and Key Contacts	5
--------------------------------------------	---

Table 2 – Acronyms	6
Table 3 – Glossary	7
Table 4 - ESCP scope relevant to SS1-9471 and SSI-9973.....	9
Table 5 - Reference Documents	9
Table 6 - Principal Contract Details	10
Table 7 - Nacap ESCP Responsibilities	11
Table 8 Erosion Risk Ratings - Rainfall	13
Table 9 – R- Factor and RUSLE Factor Assessment	13
Table 10 – Erosion and Sediment Control Measures	16
Table 11 Standard ESC Installations.....	17

LIST OF EMERGENCY AND KEY CONTACTS

Table 1 – Emergency and Key Contacts

Organisation/Position	Contact Details
Environment Line (EPA Pollution Hotline)	131 555 The Environment Line handles general inquiries about environmental issues and takes reports of pollution for which the EPA has regulatory responsibilities. Environment Line is a one-stop pollution and environmental incident reporting service provided by Environment and Heritage Group (EEG) and EPA.
Fire and Rescue NSW	000 (for pollution incidents that present an immediate threat to human health or property) 1300 729 579 (for pollution incidents that do not present an immediate threat to human health or property)
Wollongong City Council	General Enquiries (02) 4227 7111
NSW Ports	General Enquiries 1300 922 524
Port Authority NSW	24-hour community enquiries and complaints line (02) 9296 4962 enquiries@portauthoritynsw.com.au
Port Kembla Coal Terminal	Administration (02) 4228 0288
BlueScope	Laura Davis Laura.davis@bluescopesteel.com +61 467728547
Transport for NSW	General Enquiries (02) 8202 2200
GrainCorp	Dylan Clarkson +61 409 739 697 dclarkson@graincorp.com.au

Organisation/Position	Contact Details
AIE	Andrew Petch +61 401 175 917 Andrew.petch@ausindenergy.com
Jemena	Community Feedback - 1300 081 989 Justin Anderson 0435 092 889 justin.anderson@zinfra.com.au
Nacap	Jason Heard Nacap Project Manager j.heard@nacap.com.au +61 488 087 393

ACRONYMS

Table 2 – Acronyms

Term	Meaning
AIE	Australian Industrial Energy
APGA	Australian Pipelines and Gas Association
BPESC	Best Practice Erosion and Sediment Control
CEMP	Construction Environmental Management Plan
CoA	Conditions of Approval
CROW	Construction Right-of-Way
DPIE	Department of Planning, Industry and Environment
EA	Environmental Assessment
EES	Environment Energy and Science
EPA	Environment Protection Agency
ERP	Emergency Response Plan
ESC	Erosion and Sediment Control

Term	Meaning
ESCP	Erosion and Sediment Control Plan
IECA	International Erosion Control Association
LECH	Land, Environment and Cultural Heritage
PKGT	Port Kembla Gas Terminal
PKL	Port Kembla Lateral
PKPP	Port Kembla Pipeline Project
POEO Act	Protection of Environment Operations Act 1997
Principal	Jemena
SOW	Scope of Work
SSI	State Significant Infrastructure
SWMS	Safe Work Method Statements
TfNSW	Transport for NSW

GLOSSARY

Table 3 – Glossary

Term	Meaning
Company/Principal	Jemena
Contractor	Nacap
Environmental Assessment	Refers to environmental assessment undertaken in accordance with the approval and subsequent Modifications of SSI 9471 and SSI 9973.
Hazard	A source or a situation with a potential for harm in terms of human injury or ill-health, damage to property, damage to the environment, or a combination.
HAZID	Hazard Identification risk assessment

Term	Meaning
Incident	A set of circumstances that: <ul style="list-style-type: none"> > causes or threatens to cause material harm to the environment; and/or > breaches or exceeds the limits or performance measures/criteria in this approval
Project	Port Kembla Pipeline
Regulatory Requirements	Government acts and regulations that are environment specific which prescribe legal obligations encompassing the employer and contractor.
Risk	Effect of uncertainty on objectives. Often expressed in terms of a combination of the consequences of an event (including changes in circumstances) and the associated likelihood of occurrence [ISO Guide 73:2009, definition 1.1]
Sensitive Receptor	Locations where people are likely to work or reside and be affected by the works. May include residential dwellings, places of work, places of worship and areas of public open space used for recreation and access
Stakeholder	Party with vested interest in the works
Third Party	Any party external to the works that has been identified as a stakeholder

1 INTRODUCTION

1.1 Purpose and Scope

This Erosion and Sediment Control Plan (ESCP) supports the purpose and objectives outlined in the Construction Environmental Management Plan (CEMP) GAS-599-PA-EV-001 and the Soil and Water Management Sub-plan (SWMP) GAS-599-PA-EV-007 and is applicable for project based construction activities to ensure that all reasonable and practical measures are undertaken to ensure that the activities across all works do not pollute the environment in a way which causes or may cause environmental harm.

This ESCP is an Appendix of the SWMP and has been prepared to satisfy the requirements of both SSI 9471 and SSI 9973 and Environmental Protection Licence (EPL) No. 21529 including the staging of works as described in Section 1 of the CEMP and as presented in the table below.

Table 4 - ESCP scope relevant to SSI-9471 and SSI-9973

Infrastructure Approval	Post Consent Stage	Description of Works	Segment of Works As detailed in Sect 1.4 and Figure 1
SSI-9471	Stage 3	Pipeline construction from PKGT to KGMS	Segment 1.1
SSI-9973	Stage 1		Segment 1.2
			Segment 2

1.2 References

The following are principal documents referenced in this document:

Table 5 - Reference Documents

Document No.	Title of Document
GAS-554-AC-PM-001	SSI 9471 - Port Kembla Gas Terminal - Infrastructure Approval
GAS-556-AC-PM-001	SSI 9973 - Port Kembla Lateral Looping Pipeline – Infrastructure Approval including Modification 2
GAS-556-SP-PL-007	Construction Specification
GAS-551-SW-PL-001	Pipeline Construction Scope of Work
GAS-599-PA-HSE-004	Environmental Management Plan
	AIE PKGT Environmental Impact Statement (GHD) 2018
GAS-599-RP-RA-007	Jemena Eastern Gas Pipeline Looping Modification Report (Coffey) 2020
GAS-599-RP-RA-008	Jemena Eastern Gas Pipeline Looping Modification 2 Report (2022)
	Best Practice Erosion and Sediment Control (BPESC) (IECA, 2008)
	Appendix P of BPESC (IECA, 2015)
	Managing Urban Stormwater: Soils and Construction (Landcom, 2004) manual

1.3 Principal Contractor Details

Table 6 - Principal Contract Details

Nacap Details	
Business name:	Nacap Pty Ltd
Address:	Ground Floor, 599 Doncaster Road, Doncaster Victoria 3108
ABN:	33 006 306 994
Main phone number:	03 8848 1888
Contact person:	Jason Heard Nacap Project Manager
Contact mobile:	+61 488 087 393
Contact email:	j.heard@nacap.com.au

1.4 Environmental Management System Overview

The environmental management system overview is described in Section 4.1 of the CEMP. This ESCP and SWMP used together with the CEMP, and subordinate project documents, procedures, resources, and practices will inform and guide Nacap personnel and subcontractors to ensure that all reasonable and practical measures are taken to manage the environmental risks for the Project.

2 ENVIRONMENTAL PLANNING AND GOVERNANCE

The legislation, Conditions of Approval (CoA) and Environmental Management Measures (EMMs) relevant to this ESCP are outlined in Section 2 of the SWMP GAS-599-PA-EV-007.

3 EXISTING ENVIRONMENT

The existing Project environment is outlined in Section 3 of the SWMP GAS-599-PA-EV-007.

4 EROSION AND SEDIMENT CONTROL MANAGEMENT

4.1 Guidelines and Best Practices

SSI 9479 and SSI 9973 CoA prescribe minimising soil erosion associated with the construction of the pipeline in accordance with the relevant requirements in the *Managing Urban Stormwater: Soils and Construction (Landcom, 2004)* manual ('The Blue Book'), or its latest version.

Condition O4.2 of the Project EPL 21529 also prescribe that ESCs are designed constructed, operated and maintained in accordance with the 'Blue Book'. It is noted within O4.2 that the EPA may consider guidance from other industry best practice documents if it can demonstrate the guidance will provide improved outcomes for the environment and compliance with Section 120 of the POEO Act 1997.

On this basis, this ESCP has also considered guidance contained in *Best Practice Erosion and Sediment Control Appendix P – Pipeline Construction (IECA 2015)*. Its purpose is to describe the various temporary drainage, erosion and sediment control measures that are available for use during the construction of land-based pipelines, and where possible, outline the circumstances on which their use is likely to be warranted.

It is not the intent of Appendix P (IECA 2015) to over-rule the ESC standards set by the 'Blue Book'. The intent is to define, from an industry perspective, what is considered 'reasonable and practicable' with

regards to temporary erosion and sediment control measures applied during the construction of linear overland pipelines.

4.2 Roles and Responsibilities

An Organisation Chart will be developed prior to the commencement of construction and can be found in GAS-599-RC-AD-001. Refer to Appendix A of Project Management Plan (GAS-599-PA-PM-015) for Organisation Chart for ECI Phase. Position descriptions describe the responsibilities specific to positions on the Project.

Table 7 below provides a summary of Nacap environmental management responsibilities for relevant roles.

Table 7 - Nacap ESCP Responsibilities

Role	Responsibilities
Project Director (Management Representative)	<ul style="list-style-type: none"> > The Project Director provides environmental leadership and ensures that adequate, competent and experienced resources are provided and supported in the implementation of this ESCP.
Project Manager	<ul style="list-style-type: none"> > Provide support and guide in the implementation of this ESCP and associated controls > Provide management and leadership in the implementation of this ESCP > Ensure adequate resources are provided for implementing and maintaining environmental controls and mitigation measures in relation to air quality. > Take action including the stopping of work in response to natural events and activities which may impact on the environment or compromise the performance objectives, standards and commitments contained in this ESCP > Take action in the event of an environmental emergency and allocate the required resources to minimise environmental impact and harm.
Lands, Environment and Cultural Heritage (LECH) Manager	<ul style="list-style-type: none"> > Provide support and guide the implementation of this ESCP and associated controls > Provide environmental input and support to construction and associated methodologies > Support and guide site environmental incident investigation and reporting > Review internal and external project audits and coordinate the implementation of audit recommendations, and > Development, review and update of this ESCP as required.
Certified Professional in Erosion Sediment Control (CPESC)	<ul style="list-style-type: none"> > Preparing and or reviewing progressive site ESCPs prepared in accordance with BPESC. > Providing assessment and interpretation of erosion risk hazards and erosion and sediment control measures in the field. > Monitoring of completed works and compliance with this framework and BPESC. > Ensuring progressive site ESCPs are developed and documented. > Providing support to environmental incident investigation and reporting.
Environment Advisor	<ul style="list-style-type: none"> > Provide and coordinate monitoring, inspections and audits of works > Provide and coordinate site-based training preparation and delivery > Routine record keeping and reporting in support of commitments in this ESCP > Reporting of hazards and incidents and implementing any rectification measures

Role	Responsibilities
	<ul style="list-style-type: none"> > Provide site based environmental incident investigation and reporting and corrective action management.
Project Supervisors	<ul style="list-style-type: none"> > Provide leadership for the implementation of commitments contained in this ESCP > Reporting of hazards and incidents and implementing any rectification measures.
Subcontractors	<ul style="list-style-type: none"> > Subcontractors engaged to perform works on behalf of Nacap will operate in accordance with all applicable legislation, Nacap procedures and this ESCP. > Subcontractors are required to report all incidents to their Nacap Supervisor immediately.
All Project Personnel and Visitors	<ul style="list-style-type: none"> > All Project personnel and visitors will uphold a general environmental duty to take all reasonable and practical measures to ensure that the activities on the whole site do not pollute the environment in a way which causes or may cause environmental harm.

4.3 Erosion and Sediment Management Objectives

Implement all reasonable and practicable measures to:

- > Control and divert surface drainage entering the construction site
- > Control and divert surface drainage around construction disturbance and areas containing works where there may exist, a risk of contaminants being released to land or water
- > Minimise sediment release from authorised disturbance areas
- > Minimise sediment run off entering watercourses and subsequent increased turbidity and deterioration of water quality
- > Prevent contamination of surface run off and subsequent contamination of watercourses.
- > Minimise soil loss from stockpiles as a result of erosion
- > Minimise migration and cross contamination of soil groups
- > Minimise damage and erosion by site transport and construction activities
- > Ensure temporary ESC measures do not unreasonably impact upon the safety and economic attributes of approved construction works
- > Ensure permanent ESC measures are installed in accordance with the specification and drawings to restore existing drainage features, and
- > Management of overland flow including but not limited to water, including floodwater, that is flowing overland, and not in surface water body after having fallen as rain or arising from the ground.

4.4 Erosion Hazard Risk

4.4.1 Erosion Hazard Risk Assessment

Erosion hazard assessment is a procedure for undertaking a preliminary assessment of the erosion hazards associated construction activities. It is used as an indicator to determine the erosion, sediment and drainage control standards that should be applied. Given the relatively short duration and temporary nature of pipeline construction activities and the variable nature of the construction

right of way (CROW), the assessment is based on a combination of soil properties, local topography and expected rainfall conditions.

4.4.2 Erosion Hazard Risk - Topography

Review of the environmental assessment (EA) material and subsequent site visits, the CROW is considered to have a low erosion risk rating derived from Table P4 Erosion Risk Parameters (IECA 2015) where Low Risk is described as average slope gradient of the disturbance area between 3% and 5%.

4.4.3 Erosion Hazard Risk – Rainfall

Erosion risk will vary throughout the year as evident by the monthly rainfall depth for the project area. Table 8 below summarises the monthly erosion risk ratings as derived from Table P4 (IECA 2015).

Table 8 Erosion Risk Ratings - Rainfall

	Jan	Feb	Mar	Apr	Mar	Jun	Jul	Aug	Sep	Oct	Nov	Dec
Mean	116.1	157.5	183.7	92.9	89.0	140.3	62.6	87.7	55.0	108.0	94.3	90.4
Risk	High	High	High	Mod	Mod	High	Mod	Mod	Very Low	Mod	Mod	Mod

Based on the average monthly rainfall the risk is considered Moderate to High given the expected timing of the works.

4.4.4 Erosion Hazard Risk – Estimated Soil Loss

The rainfall erosivity factor is a measure of the ability of rainfall to cause erosion (referred as “R” in the Revised Universal Soil Loss Equation RUSLE). The rainfall erosivity factor is used to determine the soil loss expected in tonnes per hectare over one year.

The rainfall erosivity (R-factor) value derived from Best Practice Erosion Control (BPESC) Appendix E (IECA 2008) for Port Kembla and surrounds is presented in Table 9.

Table 9 – R- Factor and RUSLE Factor Assessment

RUSLE Parameter	Description	Adopted Value
R-Factor	Rainfall Erosivity	2,674 based on $R=164.74 (1.1177)^S S^{0.6444}$ R Average = 222/month Where S equals the 2yr – 6hr storm (11.1mm as derived from BOM)
K – Factor	Soil erodibility factor	0.04 based on silty clay loam (characterised across the alignment)
LS Factor	Topographic Factor	1.0 (default due to variance across the alignment)
C-Factor	Ground Cover	1.0 (default based on cleared construction right of way CROW)
P-Factor	Soil Conservation	1.3 (default based on cleared CROW)

The estimate of soil loss (A) is derived from $R \times K \times LS \times C \times P$

$$A = 139 \text{ tonnes /ha/ year}$$

4.4.5 Overall Erosion Hazard Risk

Based on the erosion hazard risk assessments above an overall erosion risk hazard rating of Low to Moderate is considered reasonable for the work.

This ESCP considers and applies controls for two defined erosion hazard risk levels after Table P4 of Appendix P (IECA 2015).

Level 1 – Very Low to Low (Slopes $\leq 5\%$)

Level 2 - Moderate – Extreme (Slopes $>5\%$)

For the purposes of this ESCP Slope (gradient), has been selected as a proxy at the pre-construction phase for differentiating risk level as this will have the most significant impact to erosivity and sediment impacts resulting from temporary disturbance associated with proposed pipeline construction and associated works within specified and approved works areas.

This erosion and sediment control plan outlines management and controls for Level 1 erosion hazard risks only. For Level 2 erosion hazard risks, site specific progressive ESCP(s) shall be prepared in accordance with 'Blue Book' and BPESC and be reviewed or prepared by a Certified Professional in Erosion and Sediment Control (CPESC).

The intent of this ESCP is to implement ESC that is considered reasonable and practicable with regards to the levels of erosion hazard risk encountered during pipeline construction works.

4.5 Erosion and Sediment Control Design Standards

For design purposes this ESCP adopts a Moderate erosion risk rating. For Moderate risk, Table P22 of Appendix P (IECA 2015) nominates temporary drainage and associated controls to support pipeline construction be designed for at least a 1 year ARI event.

4.6 Erosion and Sediment Control Process

4.6.1 Level 1 - Erosion and sediment controls:

Stage 1 – Pre-Construction erosion hazard assessment

- > Confirm that prescribed works areas are considered Level 1 Risk:
- > CROW longitudinal slope along the CROW and associated works areas is generally $\leq 5\%$ and may include drainage lines and waterways.
- > There is no documented assessment, soil mapping or significant visual evidence to confirm:
 - Reactive or dispersive soils within the works areas.
 - Sodic soils.
 - Non cohesive soils.
- > Should the site erosion hazard risk fall outside of these parameters at any time, apply Level 2 management which requires review of proposed ESC or the development of a site specific ESCP prepared in accordance with 'Blue Book' and BPESC by a CPESC.
- > Prior to disturbance, consult with on-site personnel for information regarding catchment sheet water flows & directions identified during previous works.
- > Utilise Project Overland Flow Assessment Reports, LiDAR and any additional relevant data provided to derive overland flow paths to develop site-specific erosion and sediment control plans.
- > Work on flood plains shall not:
 - concentrate overland water flows.
 - divert natural drainage paths.
 - increase flood duration; and
 - increase risk of detained flood flows.

- > Prior to disturbance, consult with Construction Supervisor and Works Supervisor and plan proposed actions to minimise disturbance, forward clearing and to ensure maintenance of ESC and compliance of dewatering activities where required.

Stage 2 Determine Application of ESC Standard treatments and prepare ESC Line List

- > Site assessment by Environment Manager and determination and documentation of ESC treatments including specific requirements and progressive ESC planning where required
- > Prepare ESC Line List for application of standard ESC treatments (refer to Attachment 2 for standard treatments)
- > Where required, combine Line List with diagrams of relevant ESC measures and consider use of maps if unclear.
- > Issue of ESC Line List for standard ESC treatments to Nacap Construction Superintendent and relevant supervisors.
- > Issue of progressive ESCPs and associated treatments where required.
- > Engage with Construction Supervisors with drive through site inspections to ensure all facets are understood for ESC Installation.

Stage 3 – ESC Installation

- > Construction Supervisors in consultation with Environmental Manager or delegate to implement ESC treatments as per ESC Line List.
- > Minimise as much as practicable the erosion hazard risk by limiting the extent of forward disturbance and topsoil stripping.
- > Ensure topsoil stripping is limited to prescribed depths as per the CEMP.
- > Ensure all ESC is installed within the approved CROW and extra work areas, as soon as practical prior to or following topsoil stripping.
- > Environmental Advisor to actively communicate with Operators & Crews to ensure ESC installations are fit for purpose.
- > Clearing Crew to undertake bulk earthworks and leave adequate breaks in topsoil, spoil and timber windrows for ESC structures where required.
- > Install ancillary structures including coir logs, sediment fences, sumps and additional breaks in windrows where required based on post clear and grade levels and site conditions.
- > Environment Manager to provide on-site advice and oversight of ESC installation.
- > Ensure unexpected construction conditions are managed through consultation between Environment Manager and Construction Supervisor on-site.
- > Consult with the Jemena site environment representatives where required.
- > Ensure ESC measures are re-installed when removed to facilitate pipe haulage

Stage 4 - ESC post installation review

- > Field inspection by Environment Manager or delegate or Construction Supervisor to review of ESC Register to reflect as-installed standard ESC treatments and or progressive ESC treatments where required. Consult with Jemena Representative to ensure both parties agree on any alterations and additions.

- > Consider adequacy of ESC installations and identify requirements for modifications to increase hydraulic capacity to manage water flow and sediment capture. Seek advice from CPESC as required. Record inspections of ESC installations on the Environmental Inspection Report. Report corrective actions on the Corrective Actions Register.
- > After rain events consider the overland flow water onsite. This water is to have not materially changed in its volume, velocity, direction, destination or quality, by the developed asset, ultimately during all phases of the works.

Stage 5 – ESC Maintenance

- > Construction Supervisors shall be responsible ensuring maintenance of temporary ESC structures.
- > Environment Manager or delegate shall undertake CROW inspections on a regular basis and following rainfall events and record observations and required maintenance on an Environmental Inspection report and inform the Construction Supervisor.
- > When dewatering is required, discharge points will preferentially be to vegetated areas adjacent to CROW
- > Discharge points shall be located within the approved works area or otherwise as approved by landowner/occupier and or as directed by the Jemena Representative.
- > Discharge scour protection or flow dissipation measures will be installed at the release site.
- > Dirty surface water retained within ESC structures on site is to be tested (and treated if required) before being released to ground or reused onsite (e.g., for dust suppression).
- > Any stormwater released or reused on site during dewatering events must be undertaken in accordance with the SWMP Appendix F, Dewatering and Water Reuse Protocol.
- > Required ESC maintenance to include: repair of structures, realignment of measures and excavation/reshaping of berms and sumps.
- > Where work crews modify or remove ESC structures for daily works, the responsible crew supervisor shall either reinstate the ESC structure at the end of the day or inform the Construction Supervisor who shall arrange for reinstatement of the ESC structure.

4.7 Erosion Sediment Control Measures

The following ESC measures, Table 10 shall be implemented consistent with BPESC and Appendix P (IECA 2015).

Table 10 – Erosion and Sediment Control Measures

No	Management Measure	Implementation	Responsibility
ESC1	Undertake a staged approach to the clearing of vegetation and stripping of topsoil to minimise the risk and duration of exposed subsoils	Construction	Principal Contractor/ Subcontractors
ESC2	Where possible riparian vegetation is to be left undisturbed completely or retained until works requiring removal are imminent	Construction	Principal Contractor/ Subcontractors
ESC3	Cleared vegetation to be mulched and windrowed where appropriate and placed as per the landowner line list and or access agreements	Construction	Principal Contractor/ Subcontractors
ESC4	Ensure stripped topsoil is stockpiled separately from subsoils and all stockpiles are located away from stockpiled vegetation, third party infrastructure, drainage lines and imminent flood zones	Construction	Principal Contractor/ Subcontractors
ESC5	Undertake any prescribed amelioration in accordance with the works specifications	Construction	Principal Contractor/ Subcontractors

No	Management Measure	Implementation	Responsibility
ESC6	Install signage to delineate stockpiles by soil type or to provide guidance with the location of stockpile storage areas	Construction	Principal Contractor/ Subcontractors
ESC7	Ensure topsoil stockpiles do not exceed 2m in height to avoid loss of biological properties and to retain fertility	Construction	Principal Contractor/ Subcontractors
ESC8	Stockpile vegetation and topsoil leaving appropriate gaps to enable installation of diversion measures such as inverts, berms, and discharge features (spacing as per 5.7)	Construction	Principal Contractor/ Subcontractors
ESC9	Do not use topsoil to construct diversion berms, banks, or contours	Construction	Principal Contractor/ Subcontractors
ESC10	Erosion control measures (inverts, berms, banks, and water way barriers) to be constructed to ensure discharge of diverted uncontaminated run off does not lead to erosion or sedimentation	Construction	Principal Contractor/ Subcontractors
ESC11	Ensure erosion control measures (inverts, berms, banks, and waterway barriers) extend beyond the construction area (within the CROW) with surface waters discharged around disturbance to stable, preferably vegetated areas off the CROW	Construction	Principal Contractor/ Subcontractors
ESC12	Ensure inverts, berms, banks, and water barriers are contoured to match as close as practicable to natural drainage lines or do not have excessive crossfalls, to ensure low-velocity discharge	Construction	Principal Contractor/ Subcontractors
ESC13	Ensure all silt fencing controls where required are located at toe of stockpiles, embankments, and batters	Construction	Principal Contractor/ Subcontractors
ESC14	Ensure all erosion and sediment controls other than silt fencing and sediment basins structures are constructed to permit construction traffic to move over safely without degradation to structures	Construction	Principal Contractor/ Subcontractors
ESC15	All crews are responsible for ensuring that any ESC structures modified during daily work requirements are reinstated by the end of each workday or prior to rainfall events and providing advice to the Construction Supervisor if any ESC structures require maintenance	Construction	Principal Contractor/ Subcontractors
ESC16	The Supervisor will ensure all ESC controls are maintained and in place by the end of shift on each day of works in the area of the CROW in which clear and grade activities occurred	Construction	Principal Contractor/ Subcontractors
ESC17	The Supervisor will inspect, clear accumulated sediments, and reinstate ESC controls after rain events. Relocate cleared sediments within the CROW	Construction	Principal Contractor/ Subcontractors
ESC18	Progressively rehabilitate the CROW and ensure the period between clearing remediation shall be minimised to reduce the potential for erosion	Construction	Principal Contractor/ Subcontractors
ESC19	Ensure spoil is stockpiled separately from topsoil and all stockpiles are located away from vegetation, third party infrastructure, drainage lines and imminent flood zones	Construction	Principal Contractor/ Subcontractors
ESC20	Ensure dewatering of trenches is undertaken strictly in accordance with the CEMP	Construction	Principal Contractor/ Subcontractors
ESC21	Where ESC controls are removed or modified to provide access for trenching, the Trenching Supervisor shall either reinstate the controls at day's end or notify the Construction Superintendent who shall ensure the controls are reinstated	Construction	Principal Contractor/ Subcontractors
ESC22	Inspect and maintain control measures in proper working order	Construction	Principal Contractor/ Subcontractors

4.8 Standard ESC Installations - Level 1 Erosion Hazard Risk

Nacap will utilise standard ESC drawings as per Appendix P (IECA 2015) and 'Blue Book'.

Table 11 outlines Standard ESC Designs to be used for Level 1 Erosion hazard risk works. Drawings for each installation is presented in Attachment 2:

Table 11 Standard ESC Installations

No	Description
ESCP01	Typical CROW with trench downslope of vehicle access – Figure P2 Appendix P (IECA 2015).
ESCP02	Typical CROW with trench upslope of vehicle access – Figure P2 Appendix P (IECA 2015).

No	Description
ESCP03	Drainage Control – Intermediate flow release point downslope of vehicle access track - Figure P4 Appendix P (IECA 2015).
ESCP04	Sediment Control – Downslope of vehicle access track - Figure P26 Appendix P (IECA 2015).
ESCP05	Sediment Control – Upslope of vehicle access track - Figure P27 Appendix P (IECA 2015).
ESCP06	Trafficable cross bank (berm) – Excavation upslope – Figure P5 & 6 Appendix P (IECA 2015).
ESCP07	Trafficable cross bank (berm) – Excavation downslope - Figure P7 & 8 Appendix P (IECA 2015)
ESCP08	Erosion Control – Drainage line crossing - Figure P9 Appendix P (IECA 2015).
ESCP09	Sediment Control – Drainage line crossing - Figure P13 Appendix P (IECA 2015).
ESCP10	Sediment Control – Drainage line crossing - Figure P15 Appendix P (IECA 2015).
ESCP11	Sediment Control – Drainage line crossing – Pipeline crossing downslope of access track - Figure P18 Appendix P (IECA 2015).
ESCP12	Sediment Control – Drainage line crossing – Pipeline crossing upslope of access track - Figure P19 Appendix P (IECA 2015).
ESCP13	Typical bed level crossing – Figure P30 Appendix P (IECA 2015).
ESCP14	Typical bed level crossing with flume installed – Figure P32 Appendix P (IECA 2015).
ESCP15	Drainage line crossing with pipeline downslope of access track – Figure P31 Appendix P (IECA 2015).
ESCP16	Drainage line crossing with pipeline downslope of access track with additional sediment controls – Figure P33 Appendix P (IECA 2015).
ESCP17	Waterway bed level crossing with flume with flow and trench open downslope of access track – Figure P34 Appendix P (IECA 2015).
ESCP18	Sediment Fence
ESCP19	Filter Tube Dam
ESCP20	Typical Installation of fibre rolls
ESCP21	Check Dam Sediment Trap
ESCP22	Erosion Control Blanket

These standard drawings will be supplemented by existing Standard Drawings from Jemena where appropriate to provide a range of solutions for the majority of ESC sites.

4.9 Berm Spacing

Install temporary invert, berm, and banks in accordance with the following.

- > Slopes < 1% - 200m intervals.
- > Slopes between 1 and 3 % - 100m intervals, and
- > Slopes between 3 and 5% - 80m intervals.

Install permanent berms and banks in accordance with the specification, drawings and the Reinstatement Plan (GAS-599-PA-CN-003).

4.10 Drainage Control Standards

Install typical drainage controls per BPESC:

- > Diversion of ‘clean’ up-slope run-on water either around or through the construction site.
- > Collection of ‘dirty’ runoff generated within the CROW catchment and the delivery of this water to an appropriate sediment trap.
- > Minimising the risk of soil erosion caused by site-generated flows passing along the CROW using ‘intermediate’ flow treatment and release points.

- > Control of the flow velocity of water passing through the CROW at drainage line and waterway crossings.

Following BPESC and Appendix P (IECA 2015) Table P22, Level 1 erosion hazard risks should ensure the following drainage control standards at a minimum:

- > Utilisation of CROW material windrows as flow diversion banks where required in accordance with Sect 5.5 and Attachment 2.
- > All formed drainage controls should have capacity for a 4 exceedances per year rain event.
- > In response to adverse or forecast weather conditions, drainage controls should also consider:
- > Installation of additional intermediate flow release controls beyond that specified in Sect 2.8 for upslope run on water.
- > Installation of intermediate flow and sediment controls at regular intervals for management of stormwater runoff water from the CROW catchment flowing downslope to reduce the risk and impacts of erosion and scour of the CROW.

Wherever conditions change and the Level 1 risk is exceeded, consult with a CPESC to develop, locate, and implement Level 2 controls as directed.

4.11 Waterway Crossings within Level 1 Erosion Hazard Risk Areas

- > All works to comply with the CEMP and any other associated approvals, codes, and guidelines.
- > Install ESC as per Sect 2.8 and Attachment 2 and should the erosion risk exceed Level 1 consult with a CPESC to develop, locate and implement site specific ESCP or controls as directed.
- > Wherever practicable, schedule works for periods of least flow and periods when elevated (storm related) flows are least likely.
- > Narrow the disturbance area to the minimal extent to ensure works are conducted safely.
- > Minimise and delay disturbance to the waterway below top of bank as much as practicable.
- > Give preference to use of off-stream sediment controls above the top of bank instead of instream sediment controls.
- > Avoid instream sediment controls wherever practicable and safe to do so.
- > Maintain fish passage as required
- > Ensure all soil and other material stockpiles are located outside areas of expected and forecast flows.
- > Manage runoff from required access in a manner that minimises release to the waterway i.e: diversion through sediment controls or riparian filter system upslope of waterway.
- > Where practicable and safe, ensure temporary vehicle access is at bed level and are structurally stable.
- > Ensure vehicle crossings are constructed in accordance with Jemena specification and the CEMP.
- > Ensure flow diversions in accordance with standard ESC designs at top of bank or as otherwise directed to divert run-on water away from waterway crossing disturbance.

- > Install other standard controls and as otherwise directed to provide scour protection and erosion control

4.12 Responding to Adverse or Forecast Weather Conditions

The following actions should be considered if forecast rainfall is expected to exceed monthly forecasts and intensity:

- > Where practicable schedule works to avoid periods of high rainfall intensity, in particular drainage and waterway crossings.
- > Minimise forward clearing and disturbance.
- > Formation of upslope diversion controls upslope of open excavations and trenches.
- > Stabilisation of potentially unstable diversion systems using polymers or fabrics.
- > Stabilisation of drainage and waterway crossings to protect from excessive scour events.
- > Where appropriate construct and stabilise suitable spill-through points to drainage and sediment controls to avoid overtopping that may result in structural failure.
- > Schedule reinstatement to minimise the duration of exposed subsoils.
- > Plan in consultation with Jemena representative and Construction Superintendent how ESC measures will be monitored and maintained giving consideration to safety, access and compliance with landowner line lists, access agreements and this framework.

4.13 Rehabilitation

Undertake progressive rehabilitation of the CROW in accordance with the works specification and the CEMP, the landowner line list and or access agreements.

- > Excavations along the CROW and within waterways shall be reinstated as soon as practicable after installation of the pipeline and associated works.
- > Amelioration of subsoils or topsoils to be undertaken as part of backfilling and/or CROW rehabilitation per project specifications
- > Subsoils are to be returned to the base of the excavation, and the retained topsoil containing seed bank and vegetative propagules to be placed over the backfilled trench and CROW
- > Prioritise stabilisation of the CROW through re-vegetation, use of stabilising binders and or geofabric / jute mesh / blankets. Waterway crossings to be reinstated in accordance with Jemena specification or as directed by Jemena, and.
- > Monitor and maintain temporary ESC and exclusion fencing (where required) during rehabilitation and remove progressively as site stability is restored and works acceptance is completed. .

5 MONITORING AND INSPECTIONS

The Nacap LECH Manager or delegate shall coordinate inspections and monitoring of works during construction activities and be available to provide advice and direction on the adequacy and requirement for ESC measures throughout construction; check and record compliances with works procedures and this ESCP.

Site inspections will be recorded (along with actions and issues observed) and actioned appropriately within agreed timeframes. Inspections will be recorded as part of Environmental Inspection

Checklist. Additional requirements and responsibilities in relation to inspections are documented in Section 8 of the CEMP.

To minimise the potential impacts of erosion and sediment movement, the following monitoring and reporting measures will be utilised:

- > All construction activities will be performed in accordance with the CEMP.
- > During construction, the entire length of the CROW, access routes and associated work areas will be regularly inspected to assess the effectiveness of erosion and sediment control protection measures namely.
 - Conveyance of diversion waters.
 - Site and CROW drainage.
 - Integrity and maintenance of erosion and sediment controls.
 - In advance of forecast rain events and at the conclusion of ensuing rain the active construction corridor, access routes and associated work areas will be assessed to ensure the effectiveness of erosion and sediment control protection measures.
 - Discharge to the receiving environment down-slope of the CROW and capacity to receive the release of surface flows without negative impacts to land or land use.
 - Water quality will be monitored including surface waters receiving runoff from disturbed work areas.

Works should comply with the SWMP Appendix F, Dewatering and Water Reuse Protocol. Non-compliance, hazard, and incident reporting will be implemented in accordance with Section 7 of the CEMP. Any stakeholder / landholder complaints will be managed as per Section 5.4 of the CEMP and notified to the Project Manager and appropriate corrective actions implemented including a review of work practices to ensure no repeat occurrences.

6 RECORD KEEPING AND REPORTING

6.1 Record Keeping

The Project shall maintain a documentation and record system in support of this ESCP and monthly Project HSE reporting requirements to enable review and auditing of environmental management systems and procedures.

The following records are expected to be generated in relation to soil and water management and monitoring:

- > Visual monitoring and environmental inspection records
- > Site monitoring including water quality records
- > Stakeholder discussion records
- > Induction, training and awareness records
- > Site and construction activity specific records and registers
- > Waste management records
- > Disposal Register
- > Disturbance records

- > ESCPs
- > Erosion & Sediment Control (ESC) installation registers
- > Water use records and register
- > Dewatering register
- > Reporting of Environmental Incident, non-conformances and corrective actions
- > Audit reports, and
- > Complaints.

Records will include at a minimum:

- > ESC Line Lists
- > Progressive ESCPs
- > Permanent ESCPs (As Built Records)
- > Water monitoring and laboratory testing records
- > Landowner discussion records for dewatering approvals
- > Discussion records for departure from standard ESC
- > Environmental Inspection Reports
- > Incident Reports

6.2 Reporting

Daily, Weekly, Monthly and Annual Reporting will include information on relevant environmental data and commentary as generated in support of incident and complaint management, regulatory and contractual requirements.

7 REVIEW AND IMPROVEMENT

Section 8.6 and 8.7 of the CEMP describes the process for the review and continual improvement of project documents including this ESCP.

Continual improvement of this ESCP will be achieved by ongoing evaluation of environmental management performance against environmental policies, objectives and targets, for the purpose of identifying opportunities for improvement.

The continual improvement process is designed to:

- > Identification of opportunities for improvement of environmental management and performance
- > Identification through incident investigation the cause or causes of non-conformance,
- > Development of corrective and preventative measures to address non-conformance and process deficiency
- > Assessment of the effectiveness of corrective actions
- > Documentation and communication of change and process improvements, and
- > Any updates to the ESCP as described above.

A copy of any updated plan and changes will be distributed to all relevant stakeholders and regulatory authorities. Any changes to work practices arising from document review will be communicated via pre-start alerts, toolboxes, SWMS review and or site specific awareness sessions.

ATTACHMENT 1 TYPICAL CROW LAYOUTS

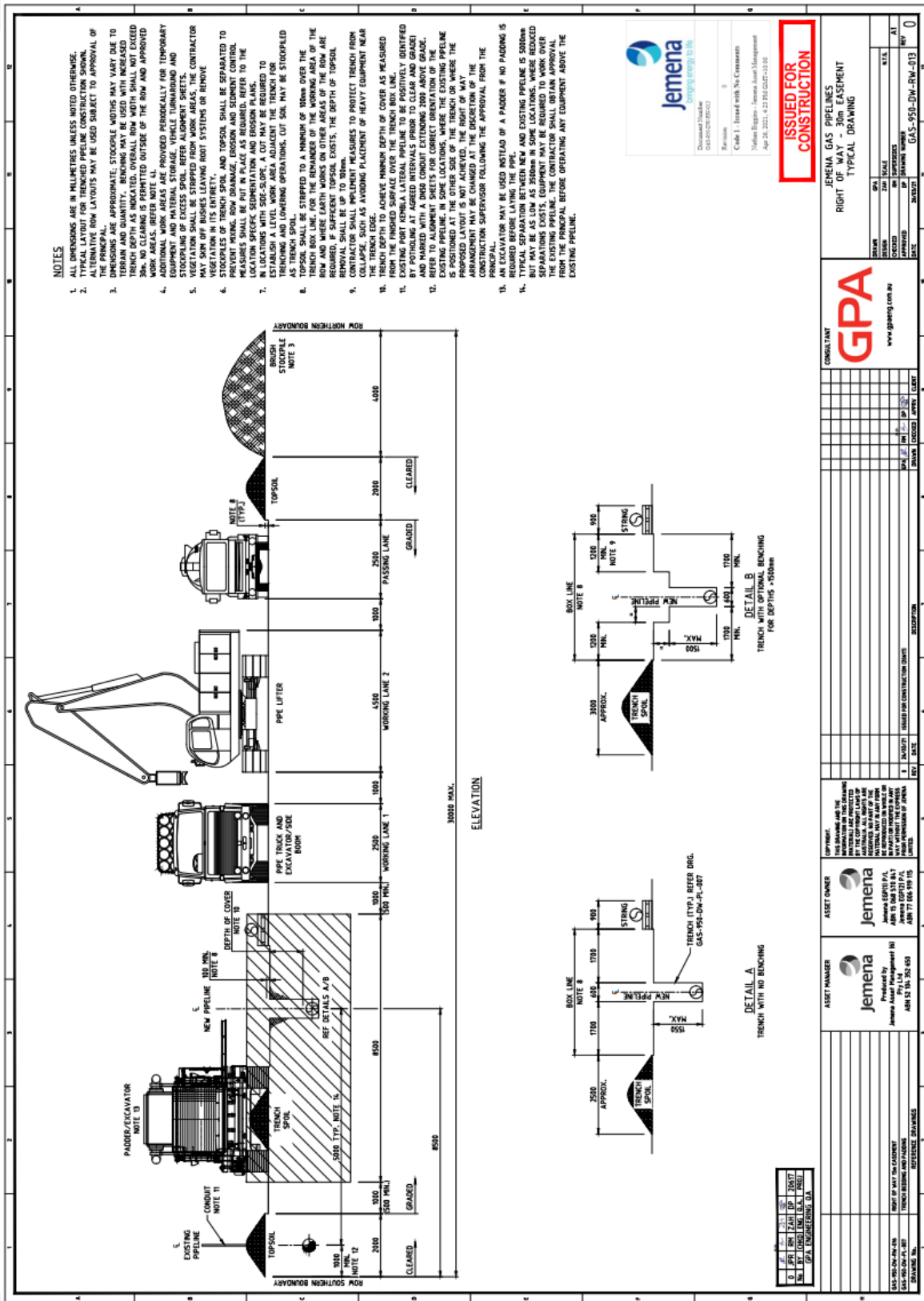

NOTES

1. ALL DIMENSIONS ARE IN MILLIMETRES UNLESS NOTED OTHERWISE.
2. TYPICAL LAYOUT FOR TRENCH PIPELINE CONSTRUCTION SHOWN. ALTERNATIVE ROW LAYOUTS MAY BE USED SUBJECT TO APPROVAL OF THE PRINCIPAL ENGINEER.
3. APPROXIMATE, STORABLE WIDTHS MAY VARY DUE TO TRENCH AND QUANTITY. BENCHING MAY BE USED WITH INCREASED TRENCH DEPTH AS INDICATED. OVERALL ROW WIDTH SHALL NOT EXCEED 55m. NO CLEARING IS PERMITTED OUTSIDE OF THE ROW AND APPROVED WORK AREAS. REFER NOTE 4).
4. ALL TRENCHES TO BE EXCAVATED PERMANENTLY FOR TEMPORARY EQUIPMENT AND MATERIAL STORAGE. VEGETATION REMOVAL AND STOCKPILING OF EXCESS SOIL. REFER ALIGNMENT SHEETS.
5. VEGETATION SHALL BE STRIPPED FROM WORK AREAS. THE CONTRACTOR MAY SOUP UP BUSHES LEAVING ROOT SYSTEMS OR REMOVE VEGETATION IN ITS ENTIRETY.
6. ALL TRENCHES SHALL BE SEPARATED TO PREVENT FLOOD DRAINAGE. EROSION AND SEDIMENT CONTROL MEASURES SHALL BE PUT IN PLACE AS REQUIRED. REFER TO THE LOCATION SPECIFIC SEDIMENTATION AND EROSION PLANS.
7. IN LOCATIONS WITH SOIL-SLIP, A CUT MAY BE REQUIRED TO PREVENT FLOOD DRAINAGE. REFER TO THE LOCATION SPECIFIC TRENCHING AND LAYING OPERATIONS. CUT SOIL MAY BE STOCKPILED AS TRENCH SPOIL.
8. THE TRENCH SHALL BE STRIPPED TO A MINIMUM OF 100mm OVER THE TRENCH BOX LINE FOR THE REMAINDER OF THE WORKING AREA OF THE ROW AND WHERE EARTH WORKS ON OTHER AREAS OF THE ROW ARE TO BE UNDERTAKEN. REFER TO THE LOCATION SPECIFIC SEDIMENTATION AND EROSION PLANS. THE DEPTH OF TOPSOIL REMOVAL SHALL BE UP TO 100mm.
9. CONTRACTOR SHALL IMPLEMENT MEASURES TO PROTECT TRENCH FROM COLLAPSE, SUCH AS AVOIDING PLACEMENT OF HEAVY EQUIPMENT NEAR THE TRENCH EDGE.
10. THE TRENCH DEPTH, EXCESS REMOVAL DEPTH, OR COVER AS MEASURED FROM THE FINISHED SURFACE OVER THE TRENCH BOX LINE.
11. EXISTING PORT KEMBLA LATERAL PIPELINE TO BE POSITIVELY IDENTIFIED BY POT-Holing AT AGREED INTERVALS (PRIOR TO CLEAR AND GRADE) AND MARKED WITH A 100mm CONDUIT EXTENDING 3000mm ABOVE GRADE. REFER TO ALIGNMENT SHEETS FOR CONDUIT IDENTIFICATION. THE CONDUIT SHALL BE PLACED AT THE OTHER SIDE OF THE TRENCH OR WHERE THE PROPOSED LAYOUT IS NOT ACHIEVED. THE RIGHT OF WAY ARRANGEMENT MAY BE CHANGED AT THE DISCRETION OF THE CONSTRUCTION SUPERVISOR FOLLOWING THE APPROVAL FROM THE ASSET OWNER.
12. AN EXCAVATOR MAY BE USED INSTEAD OF A PAUDDER IF NO PAUDDER IS REQUIRED BEFORE LAYING THE PIPE.
13. TYPICAL SEPARATION BETWEEN NEW AND EXISTING PIPELINE IS 500mm BUT MAY BE AS LOW AS 300mm IN SOME LOCATIONS, WHERE REDUCED CLEARANCE IS REQUIRED TO AVOID OVERHEAD POWER LINES. THE EXISTING PIPELINE SHALL BE POSITIVELY IDENTIFIED BY POT-Holing PRIOR TO CONSTRUCTION. OPERATING EQUIPMENT SHALL BE POSITIONED AT THE PRINCIPAL BEFORE OPERATING ANY EQUIPMENT ABOVE THE EXISTING PIPELINE.

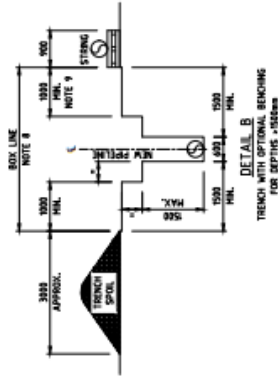
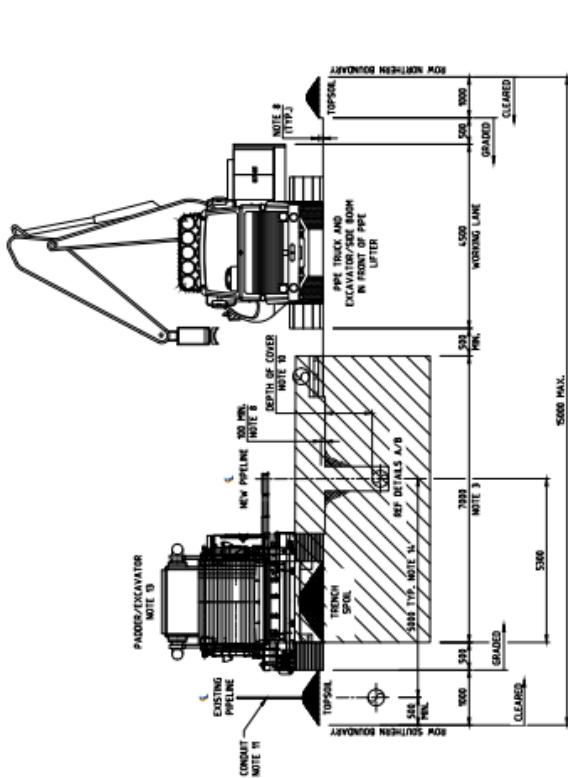

Document Number: GAS-599-PA-EV-003-01
 5/4/2024/20:08:14
 Revision: 0
 Code: J - Issued with No. Comments
 Status: Draft - Jemena Asset Management
 Per 26-2021-01-01 (CUT-01-01)

ISSUED FOR CONSTRUCTION

JEMENA GAS PIPELINES
 RIGHT OF WAY - 15m EASEMENT
 TYPICAL DRAWING

DESIGNED	DATE	APPROVED	DATE
GPA	15/11/2023	GPA	15/11/2023
CHECKED	DATE	CHECKED	DATE
GPA	15/11/2023	GPA	15/11/2023
DRAWN	DATE	DRAWN	DATE
GPA	15/11/2023	GPA	15/11/2023
PROJECT NUMBER	GAS-950-DW-RW-016		
SCALE	AS SHOWN		

CONTRACT	CONTRACT NUMBER
GPA	15/11/2023
PROJECT NUMBER	GAS-950-DW-RW-016
SCALE	AS SHOWN
DRAWN	DATE
GPA	15/11/2023
CHECKED	DATE
GPA	15/11/2023
APPROVED	DATE
GPA	15/11/2023
ISSUED FOR CONSTRUCTION DATE	DATE
15/11/2023	15/11/2023

ASSET OWNER	Jemena
ASSET NUMBER	15/11/2023
PROJECT NUMBER	GAS-950-DW-RW-016
SCALE	AS SHOWN
DRAWN	DATE
GPA	15/11/2023
CHECKED	DATE
GPA	15/11/2023
APPROVED	DATE
GPA	15/11/2023

DATE OF ANY BALANCEMENT	15/11/2023
TRENCH BENCHING AND TRENCHING	15/11/2023
REFERENCE DRAWINGS	15/11/2023
DATE	15/11/2023
SCALE	AS SHOWN
DRAWN	DATE
GPA	15/11/2023
CHECKED	DATE
GPA	15/11/2023
APPROVED	DATE
GPA	15/11/2023

ATTACHMENT 2 STANDARD ESC INSTALLATIONS

ESCP 01 - Typical CROW with trench downslope of vehicle access – Figure P2 Appendix P (IECA 2015).

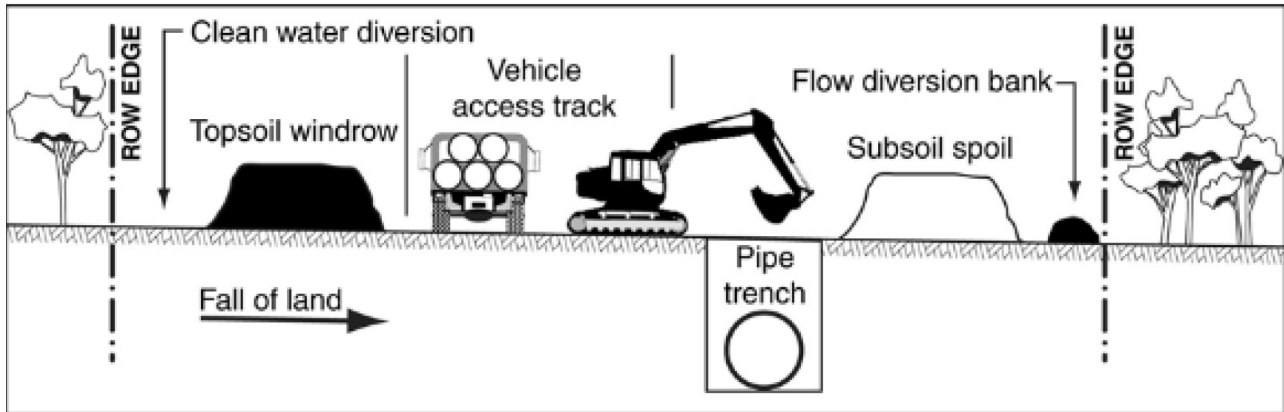

ESCP 02 - Typical CROW with trench upslope of vehicle access – Figure P2 Appendix P (IECA 2015).

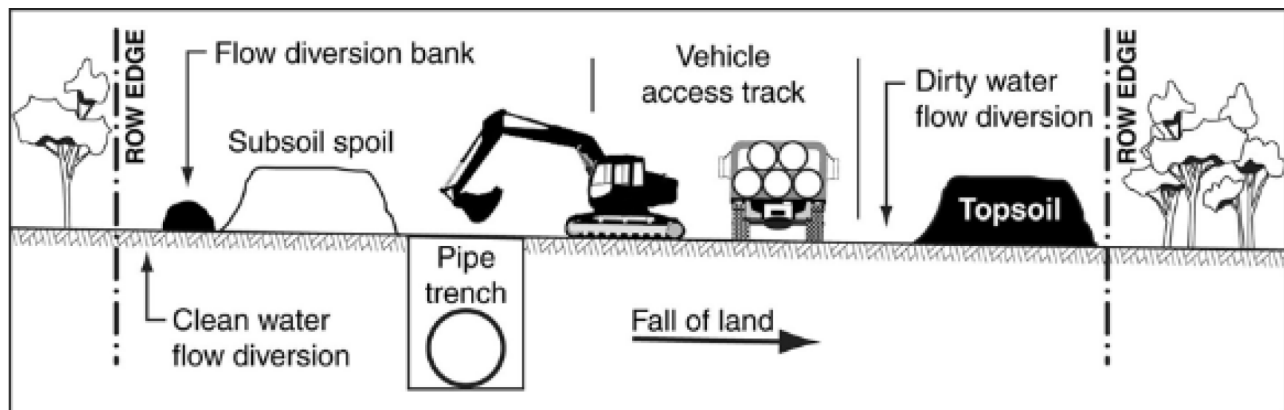

ESCP 03 - Drainage Control – Intermediate flow release point downslope of vehicle access track - Figure P4 Appendix P (IECA 2015).

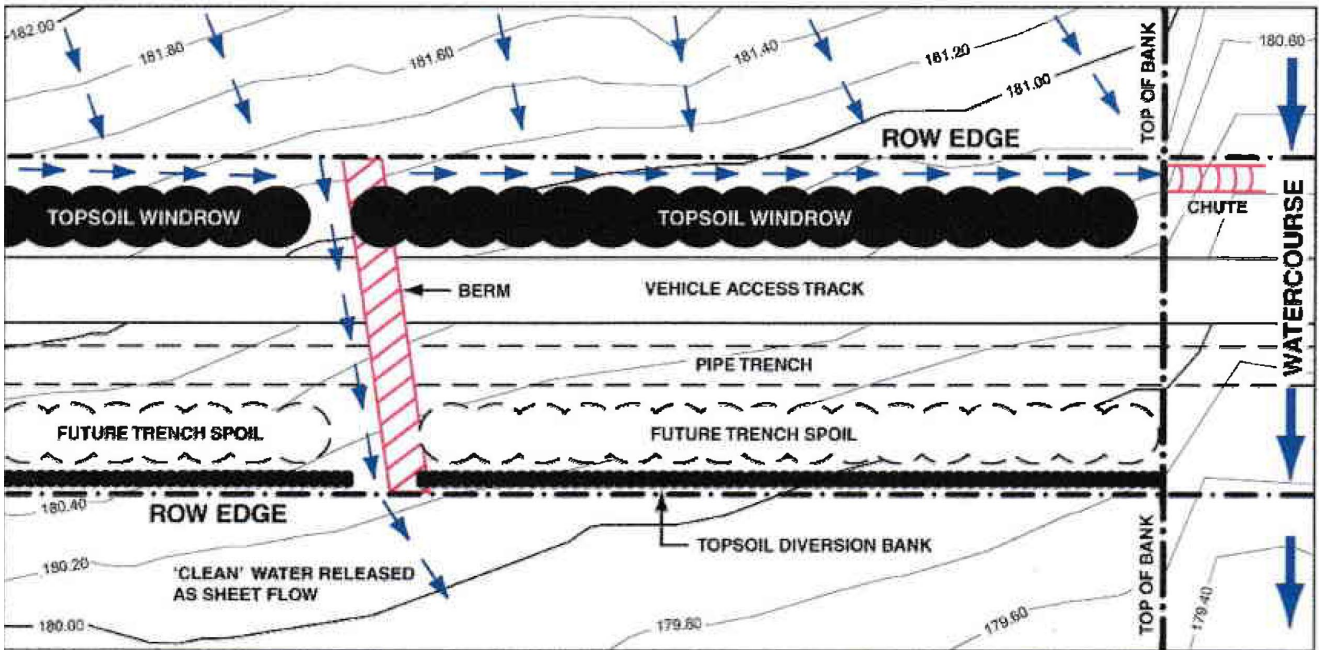

ESCP 04 - Sediment Control – Downslope of vehicle access track - Figure P26 Appendix P (IECA 2015).

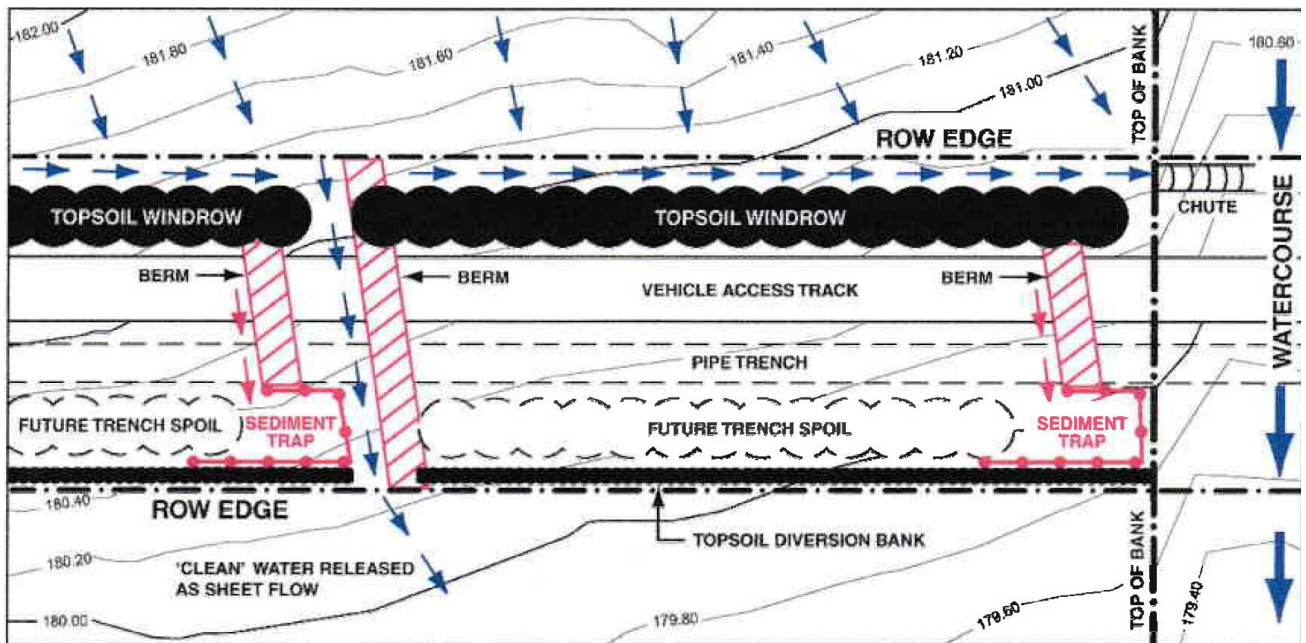

ESCP 05 – Sediment Control – Upslope of vehicle access track - Figure P27 Appendix P (IECA 2015)

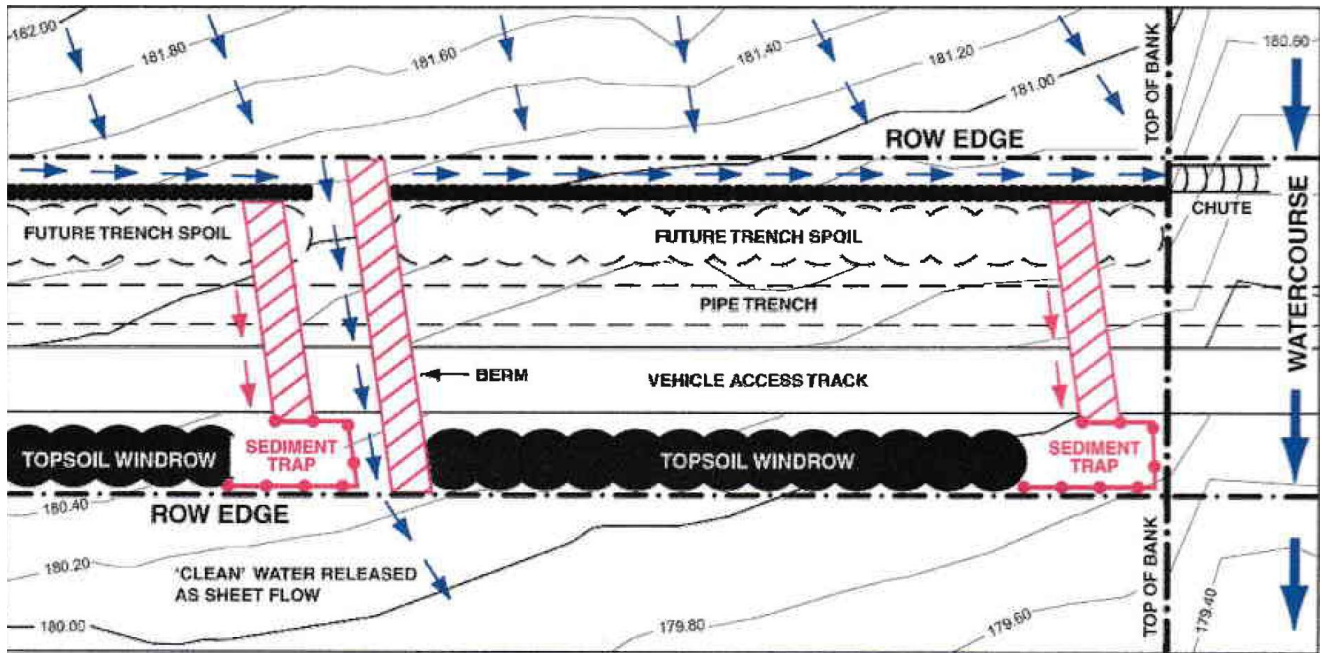

ESCP 06 – Trafficable cross bank (berm) – Excavation upslope - Figure P5 & 6 Appendix P (IECA 2015)

- Greater drainage capacity.
- Likely to require less maintenance.

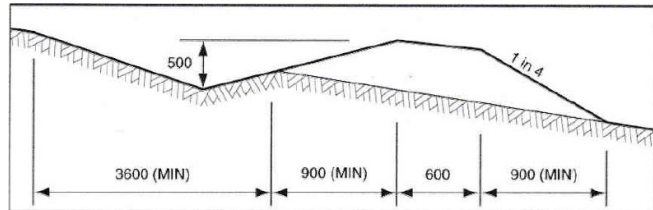
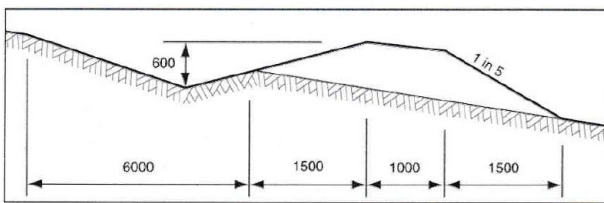

ESCP 07–Trafficable cross bank (berm) – Excavation downslope - Figure P7 & 8 Appendix P (IECA 2015)

- Invert if upslope diversion has high elevation increasing drainage capability.
- Reduced risk of exosure of problem soils upslope of the berm.

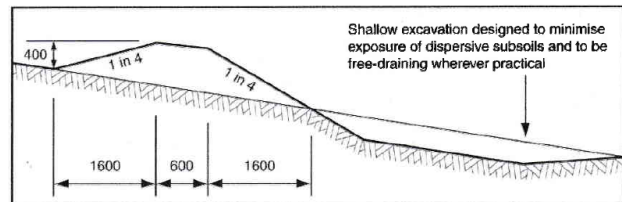
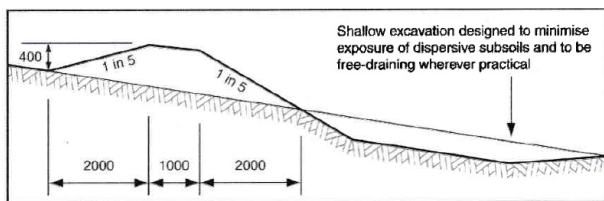

ESCP 08 – Erosion Control – Drainage line crossing - Figure P9 Appendix P (IECA 2015)

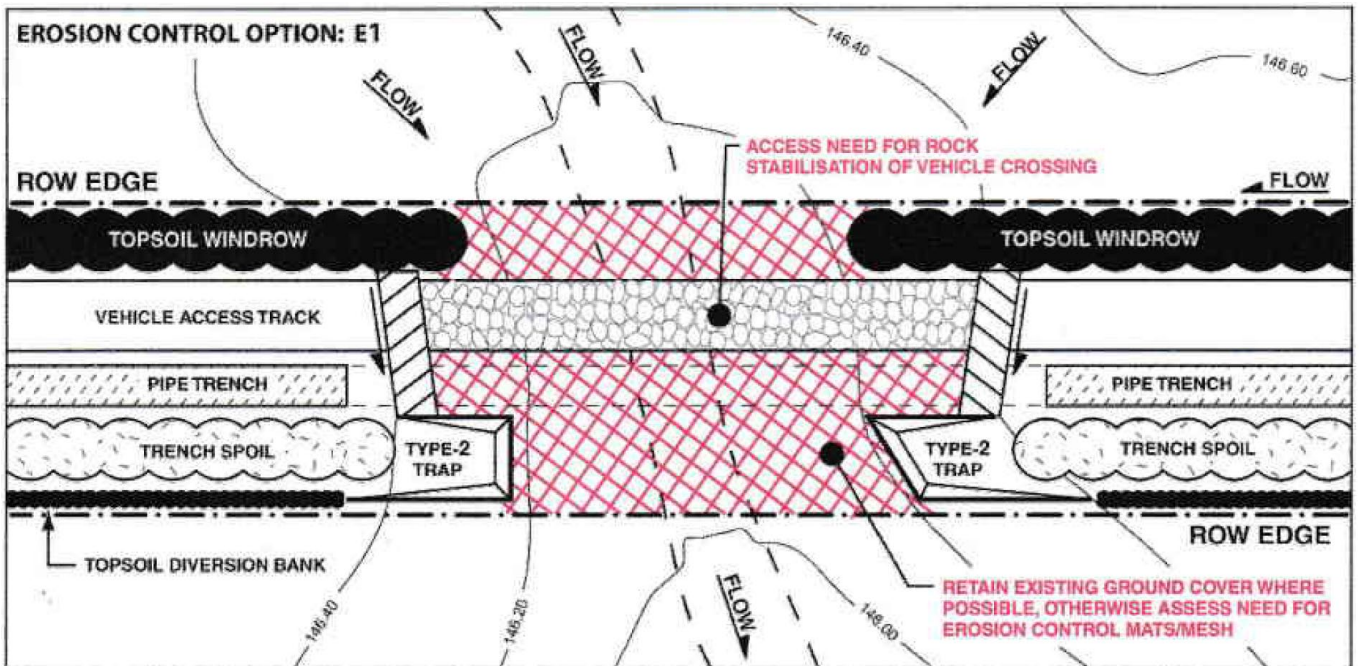

ESCP-09 – Sediment Control – Drainage line crossing - Figure P13 Appendix P (IECA 2015)

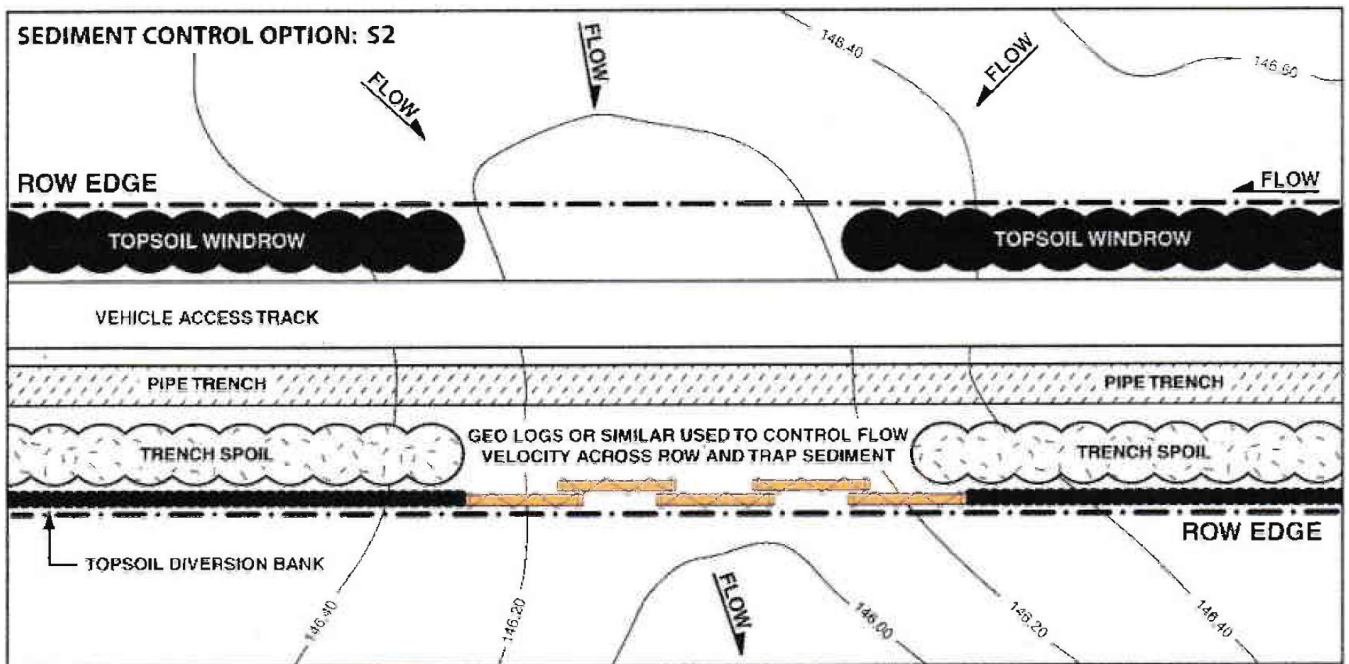

ESCP 10 – Sediment Control – Drainage line crossing - Figure P15 Appendix P (IECA 2015)

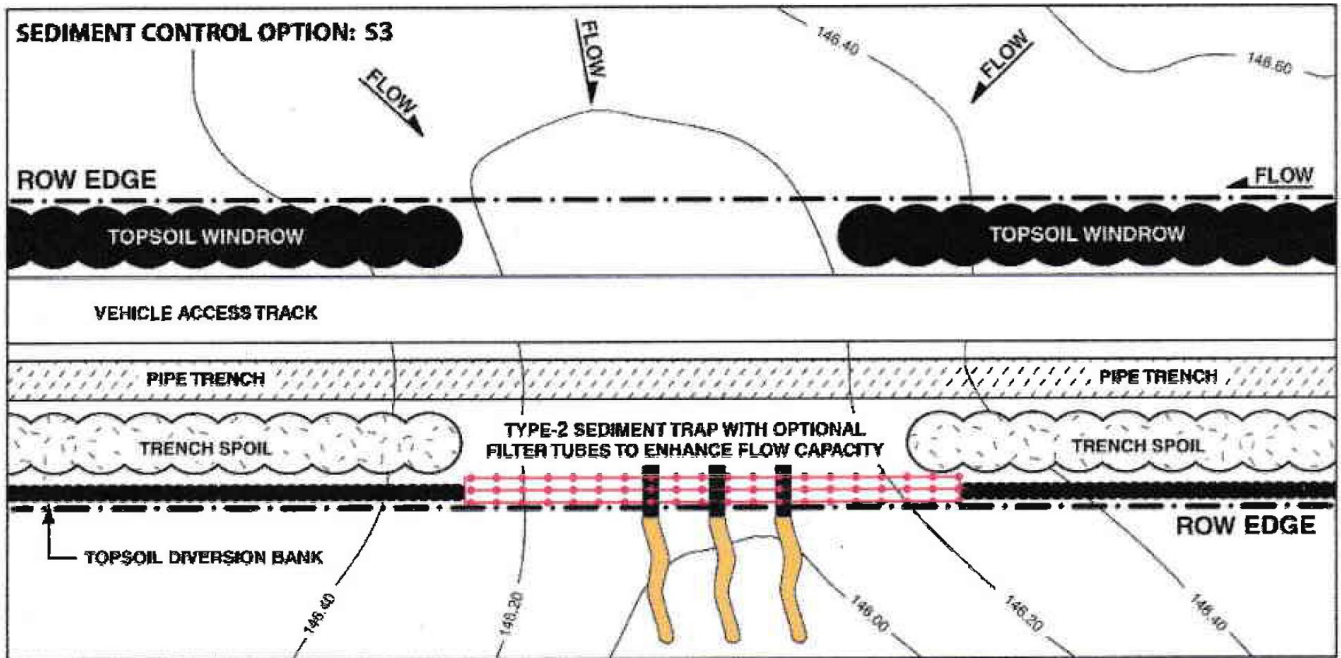

ESCP 11 – Sediment Control – Drainage line crossing – Pipeline crossing downslope of access track - Figure P18 Appendix P (IECA 2015)

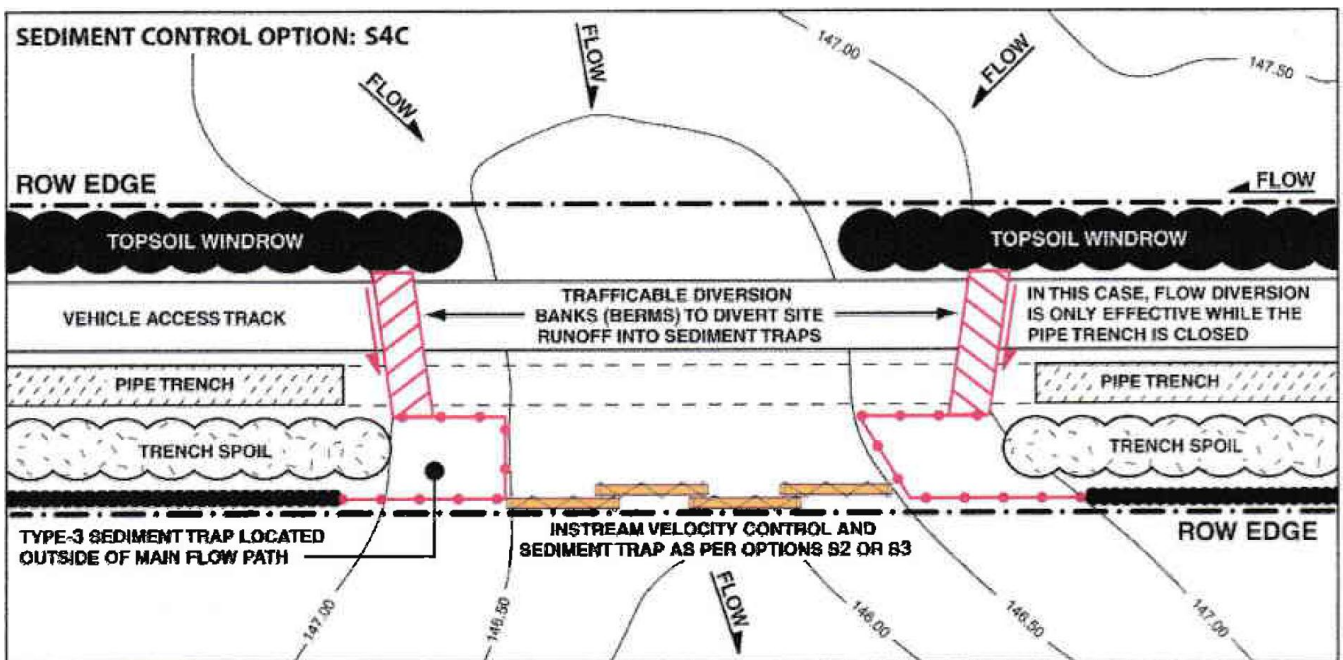

ESCP 12 – Sediment Control – Drainage line crossing – Pipeline crossing upslope of access track - Figure P19 Appendix P (IECA 2015)

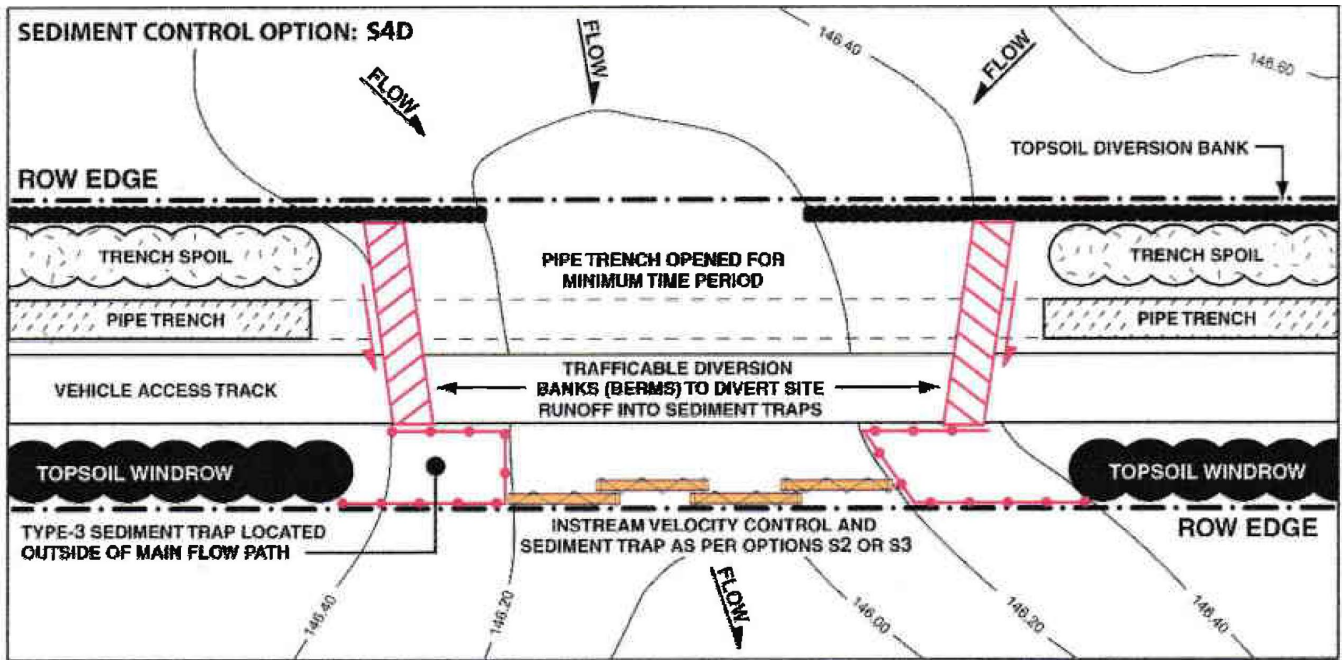

ESCP 13 – Typical bed level crossing – Figure P30 Appendix P (IECA 2015)

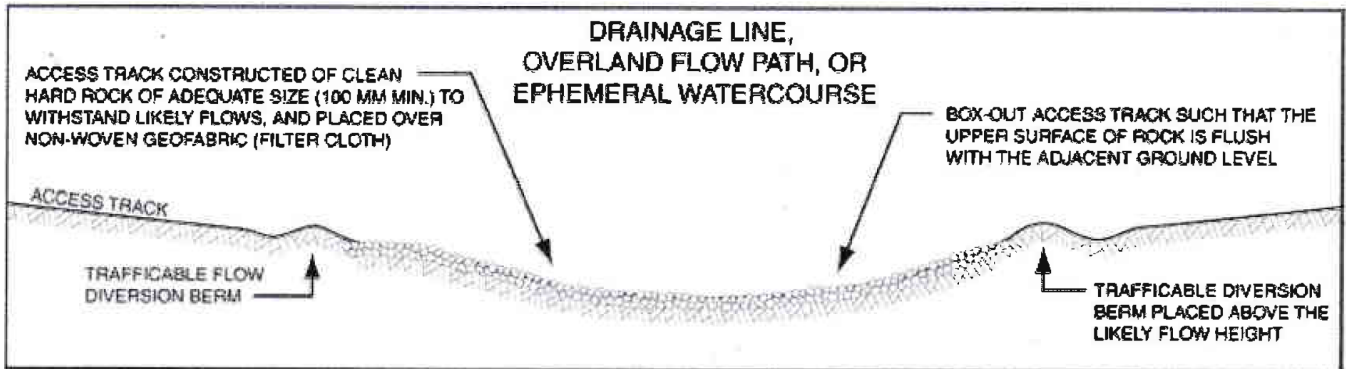

ESCP 14 – Typical bed level crossing with flume installed – Figure P32 Appendix P (IECA 2015)

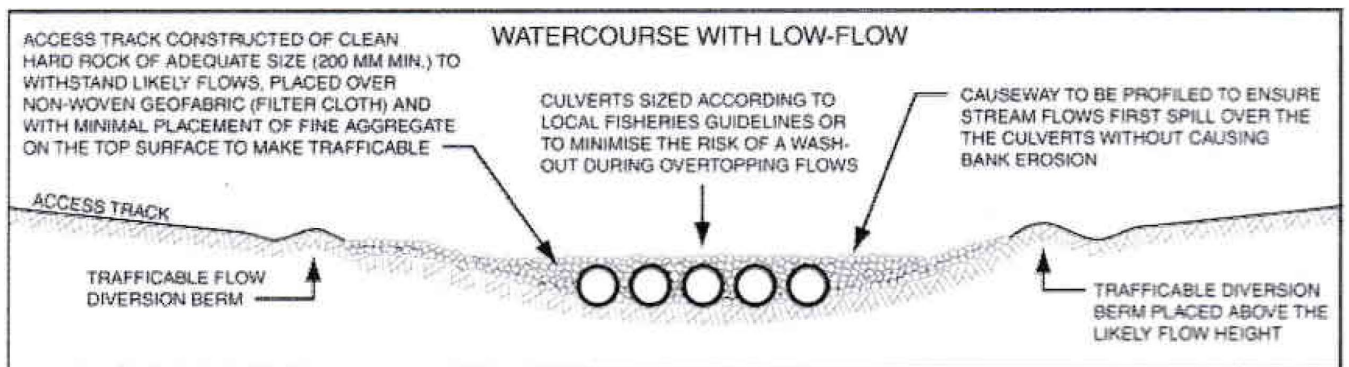

ESCP 15 – Drainage line crossing with pipeline downslope of access track – Figure P31 Appendix P (IECA 2015)

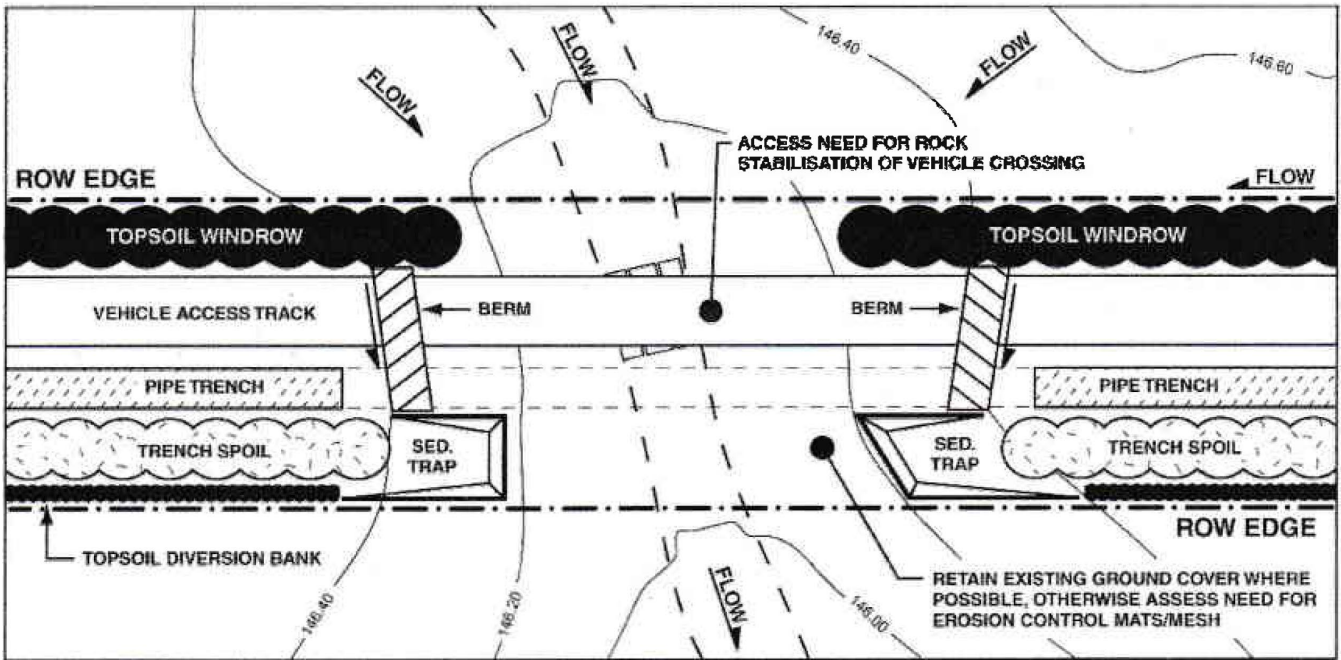

ESCP 16 – Drainage line crossing with pipeline downslope of access track with additional sediment controls – Figure P33 Appendix P (IECA 2015)

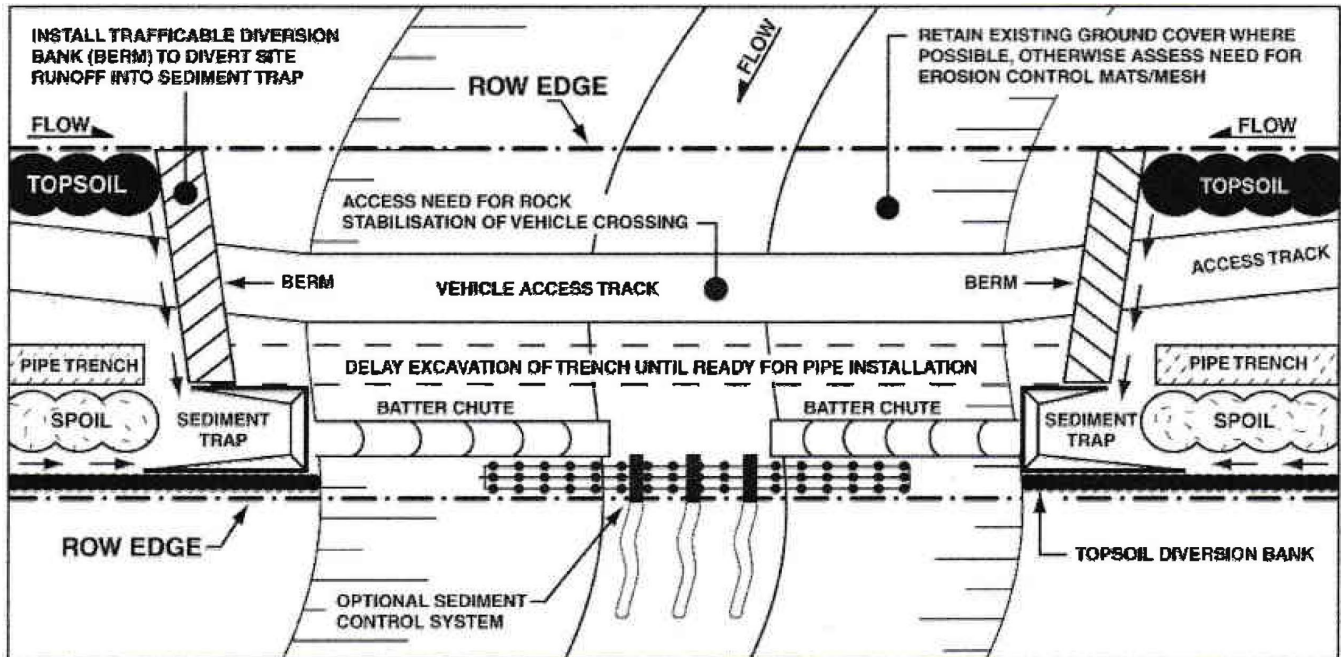

ESCP 17 – Waterway bed level crossing with flume with flow and trench open downslope of access track – Figure P34 Appendix P (IECA 2015)

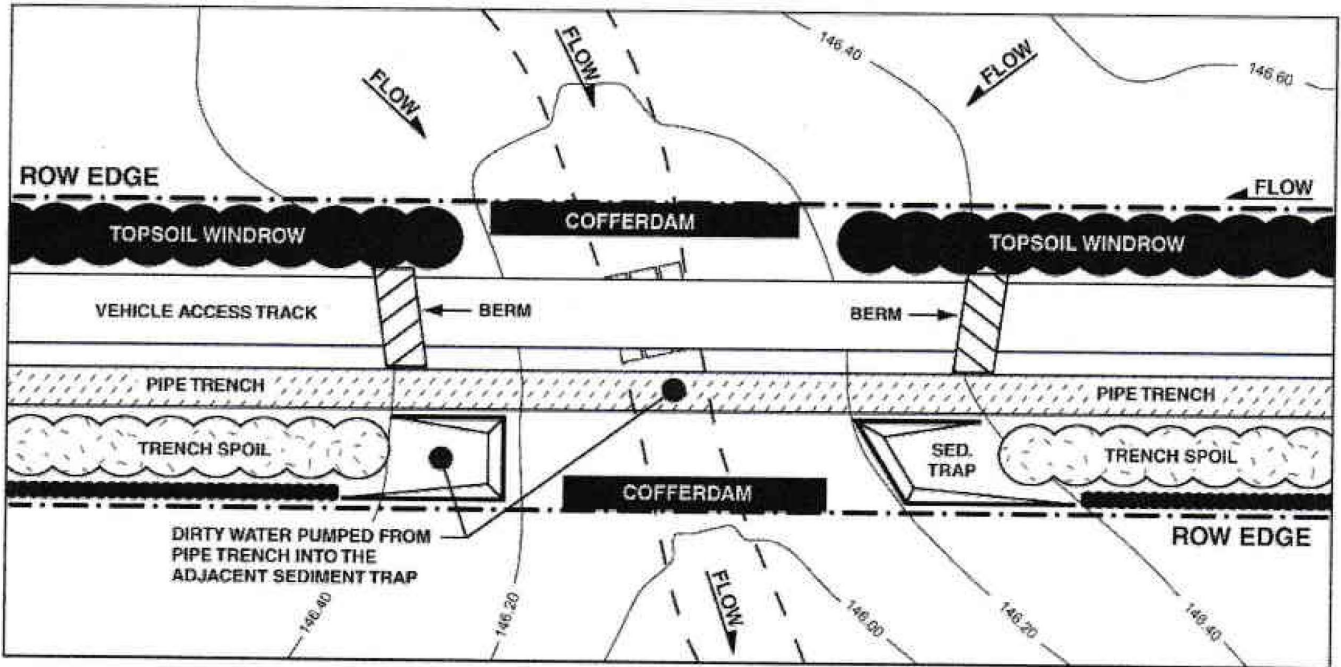

ESCP 18 – Sediment Fence

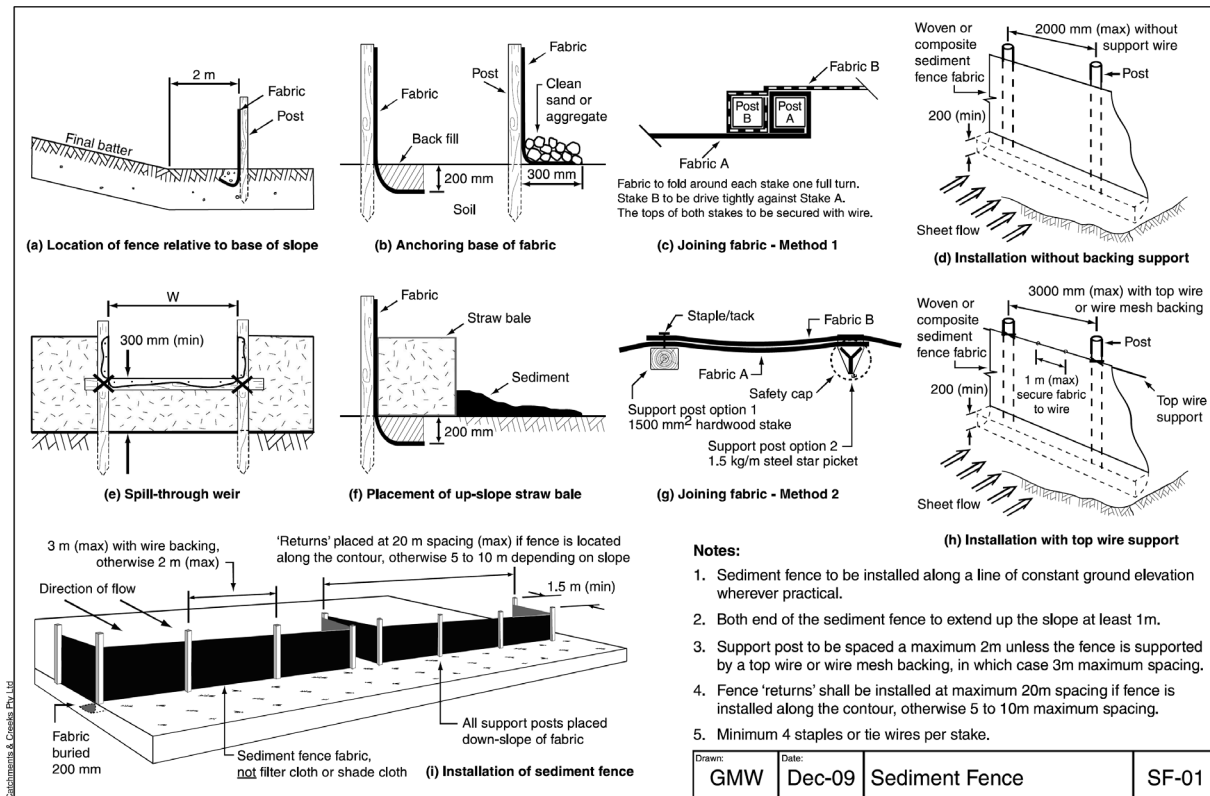

<p>MATERIALS</p> <p>FABRIC: POLYPROPYLENE, POLYAMIDE, NYLON, POLYESTER, OR POLYETHYLENE WOVEN OR NON-WOVEN FABRIC, AT LEAST 700mm IN WIDTH AND A MINIMUM UNIT WEIGHT OF 140GSM. ALL FABRICS TO CONTAIN ULTRAVIOLET INHIBITORS AND STABILISERS TO PROVIDE A MINIMUM OF 6 MONTHS OF USEABLE CONSTRUCTION LIFE (ULTRAVIOLET STABILITY EXCEEDING 70%).</p> <p>FABRIC REINFORCEMENT: WIRE OR STEEL MESH MINIMUM 14-GAUGE WITH A MAXIMUM MESH SPACING OF 200mm.</p> <p>SUPPORT POSTS/STAKES: 1500mm² (MIN) HARDWOOD, 2500mm² (MIN) SOFTWOOD, OR 1.5kg/m (MIN) STEEL STAR PICKETS SUITABLE FOR ATTACHING FABRIC.</p> <p>INSTALLATION</p> <ol style="list-style-type: none"> REFER TO APPROVED PLANS FOR LOCATION, EXTENT, AND REQUIRED TYPE OF FABRIC (IF SPECIFIED). IF THERE ARE QUESTIONS OR PROBLEMS WITH THE LOCATION, EXTENT, FABRIC TYPE, OR METHOD OF INSTALLATION CONTACT THE ENGINEER OR RESPONSIBLE ON-SITE OFFICER FOR ASSISTANCE. TO THE MAXIMUM DEGREE PRACTICAL, AND WHERE THE PLANS ALLOW, ENSURE THE FENCE IS LOCATED. <ol style="list-style-type: none"> TOTALLY WITHIN THE PROPERTY BOUNDARIES; ALONG A LINE OF CONSTANT ELEVATION WHEREVER PRACTICAL; AT LEAST 2m FROM THE TOE OF ANY FILLING OPERATIONS THAT MAY RESULT IN SHIFTING SOIL/FILL DAMAGING THE FENCE. INSTALL RETURNS WITHIN THE FENCE AT MAXIMUM 20m INTERVALS IF THE FENCE IS INSTALLED ALONG THE CONTOUR, OR 5 TO 10m MAXIMUM SPACING (DEPENDING ON SLOPE) IF THE FENCE IS INSTALLED AT AN ANGLE TO THE CONTOUR. THE 'RETURNS' SHALL CONSIST OF EITHER: <ol style="list-style-type: none"> V-SHAPED SECTION EXTENDING AT LEAST 1.5m UP THE SLOPE; OR SANDBAG OR ROCK/AGGREGATE CHECK 	<p>DAM A MINIMUM 1/3 AND MAXIMUM 1/2 FENCE HEIGHT, AND EXTENDING AT LEAST 1.5m UP THE SLOPE.</p> <ol style="list-style-type: none"> ENSURE THE EXTREME ENDS OF THE FENCE ARE TURNED UP THE SLOPE AT LEAST 1.5m, OR AS NECESSARY, TO MINIMISE WATER BYPASSING AROUND THE FENCE. ENSURE THE SEDIMENT FENCE IS INSTALLED IN A MANNER THAT AVOIDS THE CONCENTRATION OF FLOW ALONG THE FENCE, AND THE UNDESIRABLE DISCHARGE OF WATER AROUND THE ENDS OF THE FENCE. IF THE SEDIMENT FENCE IS TO BE INSTALLED ALONG THE EDGE OF EXISTING TREES, ENSURE CARE IS TAKEN TO PROTECT THE TREES AND THEIR ROOT SYSTEMS DURING INSTALLATION OF THE FENCE. DO NOT ATTACH THE FABRIC TO THE TREES. UNLESS DIRECTED BY THE SITE SUPERVISOR OR THE APPROVED PLANS, EXCAVATE A 200mm WIDE BY 200mm DEEP TRENCH ALONG THE PROPOSED FENCE LINE, PLACING THE EXCAVATED MATERIAL ON THE UP-SLOPE SIDE OF THE TRENCH. ALONG THE LOWER SIDE OF THE TRENCH, APPROPRIATELY SECURE THE STAKES INTO THE GROUND SPACED NO GREATER THAN 3m IF SUPPORTED BY A TOP SUPPORT WIRE OR WEIR MESH BACKING, OTHERWISE NO GREATER THAN 2m. IF SPECIFIED, SECURELY ATTACH THE SUPPORT WIRE OR MESH TO THE UP-SLOPE SIDE OF THE STAKES WITH THE MESH EXTENDING AT LEAST 200mm INTO THE EXCAVATED TRENCH. ENSURE THE MESH AND FABRIC IS ATTACHED TO THE UP-SLOPE SIDE OF THE STAKES EVEN WHEN DIRECTING A FENCE AROUND A CORNER OR SHARP CHANGE OF DIRECTION. WHEREVER POSSIBLE, CONSTRUCT THE SEDIMENT FENCE FROM A CONTINUOUS ROLL OF FABRIC. TO JOIN FABRIC EITHER: <ol style="list-style-type: none"> ATTACH EACH END TO TWO OVERLAPPING STAKES WITH THE FABRIC FOLDING AROUND THE ASSOCIATED STAKE ONE TURN, AND WITH 	<p>THE TWO STAKES TIED TOGETHER WITH WIRE, OR</p> <ol style="list-style-type: none"> OVERLAP THE FABRIC TO THE NEXT ADJACENT SUPPORT POST. <ol style="list-style-type: none"> SECURELY ATTACH THE FABRIC TO THE SUPPORT POSTS USING 25 X 12.5mm STAPLES, OR TIE WIRE AT MAXIMUM 150mm SPACING. SECURELY ATTACH THE FABRIC TO THE SUPPORT WIRE/MESH (IF ANY) AT A MAXIMUM SPACING OF 1m. ENSURE THE COMPLETED SEDIMENT FENCE IS AT LEAST 450mm BUT NOT MORE THAN 700mm HIGH. IF A SPILL-THROUGH WEIR IS INSTALLED, ENSURE THE CREST OF THE WEIR IS AT LEAST 300mm ABOVE GROUND LEVEL. BACKFILL THE TRENCH AND TAMP THE FILL TO FIRMLY ANCHOR THE BOTTOM OF THE FABRIC AND MESH TO PREVENT WATER FROM FLOWING UNDER THE FENCE. <p>ADDITIONAL REQUIREMENTS FOR THE INSTALLATION OF A SPILL-THROUGH WEIR</p> <ol style="list-style-type: none"> LOCATE THE SPILL-THROUGH WEIR SUCH THAT THE WEIR CREST WILL BE LOWER THAN THE GROUND LEVEL AT EACH END OF THE FENCE. ENSURE THE CREST OF THE SPILL-THROUGH WEIR IS AT LEAST 300mm THE GROUND ELEVATION. SECURELY TIE A HORIZONTAL CROSS-MEMBER (WEIR) TO THE SUPPORT POSTS/STAKES EACH SIDE OF THE WEIR. CUT THE FABRIC DOWN THE SIDE OF EACH POST AND FOLD THE FABRIC OVER THE CROSS-MEMBER AND APPROPRIATELY SECURE THE FABRIC. INSTALL A SUITABLE SPLASH PAD AND/OR CHUTE IMMEDIATELY DOWN-SLOPE OF THE SPILL-THROUGH WEIR TO CONTROL SOIL EROSION AND APPROPRIATELY DISCHARGE THE CONCENTRATED FLOW PASSING OVER THE WEIR. 	<p>MAINTENANCE</p> <ol style="list-style-type: none"> INSPECT THE SEDIMENT FENCE AT LEAST WEEKLY AND AFTER ANY SIGNIFICANT RAIN. MAKE NECESSARY REPAIRS IMMEDIATELY. REPAIR ANY TORN SECTIONS WITH A CONTINUOUS PIECE OF FABRIC FROM POST TO POST. WHEN MAKING REPAIRS, ALWAYS RESTORE THE SYSTEM TO ITS ORIGINAL CONFIGURATION UNLESS AN AMENDED LAYOUT IS REQUIRED OR SPECIFIED. IF THE FENCE IS SAGGING BETWEEN STAKES, INSTALL ADDITIONAL SUPPORT POSTS. REMOVE ACCUMULATED SEDIMENT IF THE SEDIMENT DEPOSIT EXCEEDS A DEPTH OF 1/3 THE HEIGHT OF THE FENCE. DISPOSE OF SEDIMENT IN A SUITABLE MANNER THAT WILL NOT CAUSE AN EROSION OR POLLUTION HAZARD. REPLACE THE FABRIC IF THE SERVICE LIFE OF THE EXISTING FABRIC EXCEEDS 6-MONTHS. <p>REMOVAL</p> <ol style="list-style-type: none"> WHEN DISTURBED AREAS UP-SLOPE OF THE SEDIMENT FENCE ARE SUFFICIENTLY STABILISED TO RESTRAIN EROSION, THE FENCE MUST BE REMOVED. REMOVE MATERIALS AND COLLECTED SEDIMENT AND DISPOSE OF IN A SUITABLE MANNER THAT WILL NOT CAUSE AN EROSION OR POLLUTION HAZARD. REHABILITATE/REVEGETATE THE DISTURBED GROUND AS NECESSARY TO MINIMISE THE EROSION HAZARD.
<p style="writing-mode: vertical-rl; transform: rotate(180deg);">Caldermans & Coles Pty Ltd</p>	<p>Drawn: GMW Date: Apr-10</p>	<p>Sediment Fence</p>	<p>SF-02</p>

ESCP 19 – Filter Tube Dam

<p>MATERIALS</p> <p>FILTER TUBE: MANUFACTURED FROM A NON-WOVEN GEOTEXTILE REINFORCED WITH A UV-STABILISED, WOVEN FABRIC OR POLY-PROPYLENE MESH. THE GEOTEXTILE FABRIC SHOULD BE EITHER POLYESTER OR POLYPROPYLENE. PROPERTIES (AS3706) MINIMUM WIDE STRIP TENSILE STRENGTH OF 20kN/m IN BOTH DIRECTIONS; PORE SIZE EOS LESS THAN 160MICRONS, O95 LESS THAN 90MICRONS; MINIMUM MASS OF 300GSM (MINIMUM 'BIDIM' A44 OR EQUIVALENT).</p> <p>RIBBED PIPE (USED WITH EARTH BANKS): RIBBED, PVC OR SIMILAR PIPE.</p> <p>EARTH EMBANKMENT: NON-DISPERSIVE (EMERSON'S AGGREGATE CLASS 6, 7 OR 8) CLEAN EARTH FILL, FREE OF ORGANIC DEBRIS AND WITH SUFFICIENT CLAY CONTENT TO PREVENT THE THROUGH-FLOW OF WATER.</p> <p>INSTALLATION</p> <ol style="list-style-type: none"> REFER TO APPROVED PLANS FOR LOCATION, EXTENT, AND DETAILS. IF THERE ARE QUESTIONS OR PROBLEMS WITH THE LOCATION, EXTENT, OR METHOD OF INSTALLATION CONTACT THE ENGINEER OR RESPONSIBLE ON-SITE OFFICER FOR ASSISTANCE. CONSTRUCT A SUITABLE WATER-RETAINING BARRIER/EMBANKMENT OUT OF THE MATERIAL SPECIFIED WITHIN THE APPROVED PLANS. WHILE CONSTRUCTING THE DAM OR EMBANKMENT, INSTALL AND ANCHOR THE SPECIFIED NUMBER OF RIBBED PIPE SECTIONS THROUGH THE DAM/ EMBANKMENT. 	<ol style="list-style-type: none"> ENSURE THE INLETS TO EACH FILTER TUBE ARE APPROPRIATELY ELEVATED ABOVE THE ADJACENT GROUND LEVEL TO MINIMISE THE RISK OF SEDIMENT BLOCKAGE OF THE PIPE ENTRANCE. FOR EARTH EMBANKMENT, FIRMLY HAND-TAMP THE EARTH UNDER AND AROUND THE RIPPED PIPE/S IN LIFTS NOT EXCEEDING 100mm. ENSURE THAT ALL FILL MATERIAL IS WELL-COMPACTED. FOR EARTH EMBANKMENTS, ENSURE THAT THE EMBANKMENT HAS MINIMUM DIMENSIONS OF 500mm HEIGHT, WITH 200mm CLEARANCE OVER THE PIPE OBVERT, AND MAXIMUM 2:1(H:V) SIDE SLOPES. SUITABLY CONNECT THE FILTER TUBES TO THE DOWNS-SLOPE END OF THE PROTRUDING CONNECTOR PIPES. ENSURE ALL CONNECTIONS ARE WATERTIGHT. <p>MAINTENANCE</p> <ol style="list-style-type: none"> INSPECT THE BARRIER/EMBANKMENT AND FILTER TUBES REGULARLY AND AT LEAST DAILY DURING DE-WATERING OPERATIONS. MAKE REPAIRS AS NEEDED TO THE FABRIC. INSPECT THE FILTER TUBES FOR OBVIOUS LEAKS RESULTING FROM HOLES, TEARS OR JOINT FAILURE IN THE FABRIC. REPAIR OR REPLACE ANY FILTER TUBE AS NECESSARY TO MAINTAIN THE DESIRED OPERATIONAL PERFORMANCE. IN SOME CIRCUMSTANCES FLOW RATE THROUGH THE FILTER TUBES CAN BE TEMPORARILY IMPROVED BY BRUSHING THE BAG WITH A STIFF-BRISTLED BROOM. 	<ol style="list-style-type: none"> REPLACE ANY FILTER TUBE IF SEDIMENT BLOCKAGE OF THE FABRIC DECREASES THE FLOW RATE TO AN UNACCEPTABLE LEVEL, OR THE FILTER TUBE CONTAINS EXCESSIVE SEDIMENT. <p>REMOVAL</p> <ol style="list-style-type: none"> REMOVE OF ALL MATERIALS AND DISPOSE OF THEM IN A SUITABLE MANNER THAT WILL NOT CAUSE AN ONGOING EROSION OR POLLUTION HAZARD. 	
<p style="writing-mode: vertical-rl; transform: rotate(180deg);">Caldermans & Coles Pty Ltd</p>			
	<p>(a) Filter tubes incorporated a solid, impervious dam</p>		
	<p>(b) Filter tubes incorporated into an earth embankment</p>		
	<p>Drawn: GMW Date: Apr-10</p>	<p>Filter Tube Dam</p>	<p>FTD-01</p>

ESCP 20 – Typical Installation of fibre rolls

<p>MATERIALS</p> <p>FIBRE ROLLS: TYPICALLY 200 TO 250mm JUTE, COIR OR STRAW ROLL TIED WITH SYNTHETIC OR BIODEGRADABLE MESH.</p> <p>STAKES: MINIMUM 25 x 25mm TIMBER STAKES.</p> <p>INSTALLATION</p> <ol style="list-style-type: none"> REFER TO APPROVED PLANS FOR LOCATION AND INSTALLATION DETAILS. IF THERE ARE QUESTIONS OR PROBLEMS WITH THE LOCATION, DIMENSIONS OR METHOD OF INSTALLATION CONTACT THE ENGINEER OR RESPONSIBLE ON-SITE OFFICER FOR ASSISTANCE. WHEN PLACED ACROSS NON-VEGETATED OR NEWLY SEEDED SLOPES, THE ROLLS MUST BE PLACED ALONG THE CONTOUR. IF PLACED ON OPEN OR LOOSE SOIL, ENSURE THE FIBRE ROLLS ARE TRENCHED 75 TO 125mm IN SANDY SOILS AND 50 TO 75mm IN CLAYEY SOILS. ENSURE THE OUTER MOST ENDS OF THE FIBRE ROLL ARE TURNED UP THE SLOPE TO ALLOW WATER TO ADEQUATELY POND UP-SLOPE OF THE ROLL, AND TO MINIMISE FLOW BYPASSING. WHEN PLACED ACROSS THE INVERT OF MINOR DRAINS, ENSURE THE SOCKS ARE PLACED SUCH THAT: <ol style="list-style-type: none"> THE CREST OF THE DOWNSTREAM ROLL IS LEVEL WITH THE CHANNEL INVERT AT THE IMMEDIATE UPSTREAM SOCK (IF ANY); EACH ROLL EXTENDS UP THE CHANNEL BANKS SUCH THAT THE CREST 	<p>OF THE FIBRE ROLL AT ITS LOWEST POINT IS LOWER THAN THE GROUND LEVEL AT EITHER END OF THE ROLL.</p> <ol style="list-style-type: none"> ENSURE THE ANCHORING STAKES ARE DRIVEN INTO THE END OF EACH ROLL AND ALONG THE LENGTH OF EACH ROLL AT A SPACING NOT EXCEEDING 1.2m OR SIX TIMES THE ROLL DIAMETER, WHICHEVER IS THE LESSER, A MAXIMUM STAKE SPACING OF 0.3m APPLIES WHEN USED TO FORM CHECK DAMS. ADJOINING ROLL MUST BE OVERLAP AT LEAST 450mm, NOT ABUTTED. <p>MAINTENANCE</p> <ol style="list-style-type: none"> INSPECT ALL FIBRE ROLLS PRIOR TO FORECAST RAIN, DAILY DURING EXTENDED PERIODS OF RAINFALL, AFTER SIGNIFICANT RUNOFF PRODUCING STORMS OR OTHERWISE AT WEEKLY INTERVALS. REPAIR OR REPLACE DAMAGED FIBRE ROLLS. REMOVE COLLECTED SEDIMENT AND DISPOSE OF IN A SUITABLE MANNER THAT WILL NOT CAUSE AN EROSION OR POLLUTION HAZARD. <p>REMOVAL</p> <ol style="list-style-type: none"> ALL EXCESSIVE SEDIMENT TRAPPED BY THE ROLLS MUST BE REMOVED FROM THE DRAIN OR SLOPE IF SUCH SEDIMENT IS LIKELY TO BE WASHED AWAY BY EXPECTED FLOWS. DISPOSE OF COLLECTED SEDIMENT IN A SUITABLE MANNER THAT WILL NOT CAUSE AN EROSION OR POLLUTION HAZARD. 	<ol style="list-style-type: none"> THE BIODEGRADABLE CONTENT OF THE STRAW ROLLS MAY NOT NECESSARILY NEED TO BE REMOVED FROM THE SITE. ALL SYNTHETIC (PLASTIC) MESH OR OTHER NON READILY BIODEGRADABLE MATERIAL MUST BE REMOVED FROM THE SITE ONCE THE SLOPE OR DRAIN IS STABILISED, OR THE ROLLS HAVE DETERIORATED TO A POINT WHERE THEY ARE NO LONGER PROVIDING THEIR INTENDED DRAINAGE OR SEDIMENT CONTROL FUNCTION.
-------------------------------------------------------------------------------------------------------------------------------------------------------------------------------------------------------------------------------------------------------------------------------------------------------------------------------------------------------------------------------------------------------------------------------------------------------------------------------------------------------------------------------------------------------------------------------------------------------------------------------------------------------------------------------------------------------------------------------------------------------------------------------------------------------------------------------------------------------------------------------------------------------------------------------------------------------------------------------------------------------------------------------------------------------------------------------------------------------------------------------------------------------------------------------------------------------------------------------------------------------------------------------------------	---------------------------------------------------------------------------------------------------------------------------------------------------------------------------------------------------------------------------------------------------------------------------------------------------------------------------------------------------------------------------------------------------------------------------------------------------------------------------------------------------------------------------------------------------------------------------------------------------------------------------------------------------------------------------------------------------------------------------------------------------------------------------------------------------------------------------------------------------------------------------------------------------------------------------------------------------------------------------------------------------------------------------------------------------------------------------------------------------------------------------------------------------------------------------------------------------------------------------------------------------------------------------	------------------------------------------------------------------------------------------------------------------------------------------------------------------------------------------------------------------------------------------------------------------------------------------------------------------------------------------------------------------------------------------------------------------------------------------------

Figure 1 - Typical installation of fibre rolls

Drawn:	Date:	Fibre Rolls	FR-01
GMW	Apr-10		

ESCP 21 – Check Dam Sediment Trap

<p>MATERIALS</p> <p>ROCK: 150 TO 300mm EQUIVALENT DIAMETER, HARD, EROSION RESISTANT ROCK.</p> <p>SANDBAGS: GEOTEXTILE BAGS (WOVEN SYNTHETIC, OR NON-WOVEN BIODEGRADABLE) FILLED WITH CLEAN COARSE SAND, CLEAN AGGREGATE, OR COMPOST.</p> <p>INSTALLATION (ROCK CHECK DAM)</p> <ol style="list-style-type: none"> REFER TO APPROVED PLANS FOR LOCATION AND INSTALLATION DETAILS. IF THERE ARE QUESTIONS OR PROBLEMS WITH THE LOCATION OR METHOD OF INSTALLATION CONTACT THE ENGINEER OR RESPONSIBLE ON-SITE OFFICER FOR ASSISTANCE. PRIOR TO PLACEMENT OF THE SEDIMENT TRAP, ENSURE THE DRAINAGE CHANNEL IS DEEP ENOUGH TO PREVENT WATER BEING UNSAFELY DIVERTED OUT OF THE DRAIN ONCE THE CHECK DAMS ARE INSTALLED. LOCATE EACH CHECK DAM SEDIMENT TRAP AS DIRECTED WITHIN THE APPROVED PLANS, OR OTHERWISE AT SUCH A SPACING TO ACHIEVE THE REQUIRED SEDIMENT TRAPPING OUTCOMES. IF THE CHECK DAMS ARE ALSO BEING USED TO CONTROL EROSION WITHIN THE DRAINAGE CHANNEL, THEN LOCATE EACH SUCCESSIVE CHECK DAM SUCH THAT THE CREST OF THE IMMEDIATE DOWNSTREAM DAM IS LEVEL WITH THE CHANNEL INVERT AT THE IMMEDIATE UPSTREAM CHECK DAM. CONSTRUCT EACH CHECK DAM TO THE DIMENSIONS AND PROFILE SHOWN WITHIN THE APPROVED PLAN. WHERE SPECIFIED, THE CHECK DAMS MUST BE CONSTRUCTED ON A SHEET OF GEOTEXTILE FABRIC USED AS A DOWNSTREAM SPLASH PAD. EACH CHECK DAM MUST BE EXTENDED UP THE CHANNEL BANK (WHERE PRACTICABLE) TO AN ELEVATION AT LEAST 150mm ABOVE THE CREST LEVEL OF THE DAM. 	<p>INSTALLATION (COMPOST-FILLED SOCKS)</p> <ol style="list-style-type: none"> REFER TO APPROVED PLANS FOR LOCATION AND INSTALLATION DETAILS. IF THERE ARE QUESTIONS OR PROBLEMS WITH THE LOCATION OR METHOD OF INSTALLATION CONTACT THE ENGINEER OR RESPONSIBLE ON-SITE OFFICER FOR ASSISTANCE. PRIOR TO PLACEMENT OF THE SEDIMENT TRAP, ENSURE THE DRAINAGE CHANNEL IS DEEP ENOUGH TO PREVENT WATER BEING UNSAFELY DIVERTED OUT OF THE DRAIN ONCE THE CHECK DAMS ARE INSTALLED. LOCATE EACH SOCK AS DIRECTED WITHIN THE APPROVED PLANS, OR OTHERWISE AT SUCH A SPACING TO ACHIEVE THE REQUIRED SEDIMENT TRAPPING OUTCOMES. PLACE EACH SOCK TO THE LINES AND PROFILE SHOWN IN THE APPROVED PLAN OR AS DIRECTED BY THE SITE SUPERVISOR. ENSURE EACH SOCK EXTENDS UP THE CHANNEL BANKS (WHERE PRACTICAL) TO A LEVEL AT LEAST 100mm ABOVE THE CREST LEVEL OF THE CHECK DAM. <p>MAINTENANCE</p> <ol style="list-style-type: none"> INSPECT EACH CHECK DAM AND THE DRAINAGE CHANNEL AT LEAST WEEKLY AND AFTER RUNOFF-PRODUCING RAINFALL. CORRECT ALL DAMAGE IMMEDIATELY. IF SIGNIFICANT EROSION OCCURS BETWEEN ANY OF THE CHECK DAMS, THEN CHECK THE SPACING OF THE DAMS AND WHERE NECESSARY INSTALL INTERMEDIATE CHECK DAMS OR A SUITABLE CHANNEL LINER. CHECK FOR DISPLACEMENT OF THE CHECK DAMS. CHECK FOR SOIL SCOUR AROUND THE ENDS OF EACH CHECK DAM. IF SUCH EROSION IS OCCURRING, CONSIDER EXTENDING THE WIDTH OF THE CHECK DAM TO AVOID SUCH PROBLEMS. 	<ol style="list-style-type: none"> IF SEVERE SOIL EROSION OCCURS EITHER UNDER OR AROUND THE CHECK DAMS, THEN SEEK EXPERT ADVICE ON AN ALTERNATIVE TREATMENT MEASURE. DE-SILT SEDIMENT TRAP IF THE SEDIMENT LEVEL EXCEEDS 1/3 THE CREST HEIGHT. DISPOSE OF COLLECTED SEDIMENT IN A SUITABLE MANNER THAT WILL NOT CAUSE AN EROSION OR POLLUTION HAZARD. <p>REMOVAL</p> <ol style="list-style-type: none"> WHEN CONSTRUCTION WORK WITHIN THE DRAINAGE AREA ABOVE THE CHECK DAMS HAS BEEN COMPLETED AND DISTURBED AREAS SUFFICIENTLY STABILISED TO RESTRAIN EROSION, THE DAMS MUST BE REMOVED, UNLESS THE SEDIMENT TRAPS ARE TO REMAIN AS A PERMANENT FEATURE. REMOVE COLLECTED SEDIMENT AND DISPOSE OF IN A SUITABLE MANNER THAT WILL NOT CAUSE AN EROSION OR POLLUTION HAZARD. REMOVE AND APPROPRIATELY DISPOSE OF ALL MATERIALS INCLUDING ANY GEOTEXTILE FABRIC. STABILISE THE DISTURBED CHANNEL WITH A LINING OF FABRIC AND ROCK, OR ESTABLISH VEGETATION AS APPROPRIATE.
-----------------------------------------------------------------------------------------------------------------------------------------------------------------------------------------------------------------------------------------------------------------------------------------------------------------------------------------------------------------------------------------------------------------------------------------------------------------------------------------------------------------------------------------------------------------------------------------------------------------------------------------------------------------------------------------------------------------------------------------------------------------------------------------------------------------------------------------------------------------------------------------------------------------------------------------------------------------------------------------------------------------------------------------------------------------------------------------------------------------------------------------------------------------------------------------------------------------------------------------------------------------------------------------------------------------------------------------------------------------------------------------------------------------------------------------------------------------------------------------------------------------------------------------------------------------------------------------------	-----------------------------------------------------------------------------------------------------------------------------------------------------------------------------------------------------------------------------------------------------------------------------------------------------------------------------------------------------------------------------------------------------------------------------------------------------------------------------------------------------------------------------------------------------------------------------------------------------------------------------------------------------------------------------------------------------------------------------------------------------------------------------------------------------------------------------------------------------------------------------------------------------------------------------------------------------------------------------------------------------------------------------------------------------------------------------------------------------------------------------------------------------------------------------------------------------------------------------------------------------------------------------------------------------------------------------------------------------------------------------------------------------------------------------------------------------------------------------------------------------------------------------------------------------------------------	-------------------------------------------------------------------------------------------------------------------------------------------------------------------------------------------------------------------------------------------------------------------------------------------------------------------------------------------------------------------------------------------------------------------------------------------------------------------------------------------------------------------------------------------------------------------------------------------------------------------------------------------------------------------------------------------------------------------------------------------------------------------------------------------------------------------------------------------------------------------------------------------------------------------------------------------------------------------------------------------------------------------------------------------------------------

Figure 1 - Placement of check dam sediment traps

Drawn:	Date:	Check Dam Sediment Trap	CDT-01
GMW	Apr-10		

ESCP 22 – Erosion Control Blankets

MATERIALS

UNLESS OTHERWISE SPECIFIED, THE FOLLOWING MATERIAL SPECIFICATIONS SHOULD APPLY.

GEOTEXTILE BLANKETS:

- (i) WOVEN POLYPROPYLENE FABRIC.
- (ii) MINIMUM THICKNESS OF 1.5mm.
- (iii) MINIMUM WIDTH OF 3.6m.

STAPLES:

- (i) MINIMUM 11 GAUGE STEEL WIRE.
- (ii) U-SHAPED WITH 200mm LEG LENGTH AND 50mm CROWN.

EXCELSIOR BLANKETS:

- (i) CURLED WOOD FIBRE BLANKET WITH 80% OF FIBRES LONGER THAN 150mm.
- (ii) MINIMUM ROLL WIDTH OF 1200mm.
- (iii) AVERAGE WEIGHT OF 0.43kg/m² +/- 10%.

STRAW BLANKETS:

- (i) MINIMUM ROLL WIDTH OF 2m.
- (ii) MINIMUM WEIGHT OF 0.27kg/m².

COCONUT FIBRE BLANKETS:

- (i) MINIMUM ROLL WIDTH OF 2m.
- (ii) MINIMUM WEIGHT OF 0.27kg/m².

INSTALLATION

THE METHOD OF INSTALLATION VARIES WITH THE TYPE OF MATERIAL USED AND THE TASK BEING PERFORMED BY THE BLANKET. INSTALLATION PROCEDURES SHOULD BE SUPPLIED BY THE MANUFACTURER OR DISTRIBUTOR OF THE PRODUCT. A TYPICAL INSTALLATION PROCEDURE FOR ROLLED EROSION CONTROL PRODUCTS IS DESCRIBED BELOW.

APPLICATION OF ROLLED BLANKETS ON SLOPES NOT SUBJECTED TO CONCENTRATED FLOW:

1. REFER TO APPROVED PLANS FOR LOCATION, EXTENT, AND INSTALLATION DETAILS. IF THERE ARE QUESTIONS OR PROBLEMS WITH THE LOCATION, EXTENT, OR METHOD OF INSTALLATION CONTACT THE ENGINEER OR RESPONSIBLE ON-SITE OFFICER FOR ASSISTANCE.

2. CLEAR AWAY TRASH AND LARGE STONES, AND GRADE SMOOTHLY TO ELIMINATE FOOTPRINTS, TRACKS AND RUTS.

3. PREPARE A SMOOTH SEEDBED OF APPROXIMATELY 75mm OF TOPSOIL.

4. APPLY SEED, SOIL AMELIORANTS AND WATER AS SPECIFIED, THEN RAKE TO REMOVE ANY REMAINING SURFACE IRREGULARITIES.

5. COMMENCE PLACEMENT OF THE BLANKETS AT THE TOP OF THE SLOPE. BURY THE UPPER EDGE OF THE BLANKET WITHIN A 300mm DEEP TRENCH AND STAPLE AT 200 TO 250mm CENTRES.

6. THE BLANKETS CAN BE PLACED LENGTHWISE EITHER ALONG THE SLOPE (PARALLEL TO THE CONTOURS) OR DOWN THE SLOPE (TRANSVERSE TO THE CONTOURS), BUT NOT DIAGONALLY ACROSS THE SLOPE.

7. OVERLAP THE SIDES OF EACH BLANKET BY AT LEAST 100mm.

8. BURY THE EDGE OF THE BLANKET LOCATED ALONG THE OUTER MOST EDGE OF THE TREATED AREA WITHIN A 300mm DEEP TRENCH AND STAPLE THE BLANKET WITHIN THE TRENCH AT 200 TO 250mm CENTRES.

9. WHERE MORE THAN ONE BLANKET IS USED DOWN THE SLOPE, OVERLAP EACH BLANKET BY AT LEAST 300mm WITH THE UPPER BLANKET PLACED OVER THE LOWER BLANKET (SHINGLE STYLE).

10. WHEN SPREADING THE BLANKETS, AVOID STRETCHING THE FABRIC. THE BLANKETS SHOULD REMAIN IN GOOD CONTACT WITH THE SOIL.

11. STAPLE THE EXPOSED FABRIC SURFACE AT 1m CENTRES.

12. BLANKETS, ONCE FIXED, MAY BE ROLLED WITH A ROLLER WEIGHING 60 TO 90kg/m LENGTH, THEN WATERED.

13. THE INSTALLATION PROCEDURE MUST ENSURE THAT THE BLANKET ACHIEVES AND RETAINS INTIMATE CONTACT WITH THE SOIL.

14. DAMAGED FABRIC SHALL BE REPAIRED OR REPLACED.

15. WHERE DIRECTED, AN ADDITIONAL MESH (JUTE OR COIR) ANCHOR MAY NEED TO BE PLACED OVER THE BLANKETS TO MINIMISE DISPLACEMENT BY STRONG WINDS.

ADDITIONAL REQUIREMENTS ASSOCIATED WITH USE NEAR AIRPORT PAVEMENTS:

1. ONLY BLANKETS THAT ARE DOUBLE NETTED SHALL BE ALLOWED WITHIN 3m OF ANY AIRPORT PAVEMENT USED BY AIRCRAFT WITH THE EXCEPTION OF AIRPORTS CLASSIFIED AS AIR CARRIER OR CORPORATE/TRANSPORT. IF THE AIRPORT IS CLASSIFIED AS AN AIR

CARRIER OR CORPORATE/TRANSPORT, THERE WILL BE NO BLANKETS ALLOWED WITHIN 9m OF PAVEMENT USED BY AIRCRAFT.

2. ONLY BIODEGRADABLE ANCHORING DEVICES SHALL BE ALLOWED IN THE INSTALLATION OF ANY BLANKET FOR AIRPORT APPLICATIONS. NO METAL STAPLES WILL BE ALLOWED.

MAINTENANCE

1. DURING THE ACTIVE CONSTRUCTION PERIOD, INSPECT THE TREATED AREA FORTNIGHTLY AND AFTER RUNOFF-PRODUCING STORM EVENTS AND MAKE REPAIRS AS NEEDED.

2. THE TREATED AREA SHOULD BE INSPECTED AT LEAST FORTNIGHTLY FOR THE FIRST 3 MONTHS.

3. INSPECT THE TREATED AREA TO SEE IF:

- (i) CONSTRUCTION ACTIVITY OR FALLING DEBRIS HAVE DAMAGED THE BLANKETS;
- (ii) RUNOFF IS UNDERMINING THE FABRIC;
- (iii) THE BLANKETS ARE IN GOOD CONTACT WITH THE SOIL; AND
- (iv) THE BLANKETS MAINTAIN ADEQUATE OVERLAP.

4. IF DAMAGED, REPAIR OR REPLACE THE DAMAGED SECTION. IF WATER IS UNDERMINING THE FABRIC, REPAIR ANY HOLES OR JOINTS OR RE-BURY THE UPPER ENDS OF THE DAMAGED SECTIONS.

Catchments & Coirtek Pty Ltd

Drawn:	Date:		
GMW	May-10	Erosion Control Blankets	ECB-01





APPENDIXD UNEXPECTED CONTAMINATED LAND FINDS PROCEDURE

Jemena

Port Kembla Pipeline Project

UNEXPECTED CONTAMINATED LAND FINDS PROCEDURE

Document No.: GAS-599-PR-CN-001 | Revision 3

3	Issued for Use	BRO 	RPO 	BPH 	JHE 	18-NOV-2022
2	Issued for Use	BRO	HHE	BPH	JHE	28-SEP-2022
1	Issued for Use	BRO	BPH	NFU	BKE	1-AUG-2022
0	Issued for Use	BRO	ZFR	NFU	JHE	31-MAY-2022
A	Issued for Review	BRO	ZFR	NFU	JHE	6-MAY-2022
Rev	Description	By	Checked	QA	Nacap Approved	Date

REVISION HISTORY

This table describes changes made for numerical revisions after Rev 0

Date	Rev	By	Description
1/8/2022	1	BRO	Update of Emergency Contact details for Approvals consultation
28/9/2022	2	BRO	Update following AIE Review (Site Auditor)
18/11/2022	3	BRO	Updated following DPE Review

CONTENTS

ACRONYMS 5
GLOSSARY..... 6
1 INTRODUCTION 8
 1.1 Purpose and Scope..... 8
 1.2 References..... 8
 1.3 Principal Contractor Details..... 8
 1.4 Environmental Management System Overview..... 9
2 ENVIRONMENTAL PLANNING AND GOVERNANCE 9
3 EXISTING ENVIRONMENT 9
 3.1 Contamination..... 9
 3.2 Acid Sulfate Soils..... 10
4 UNEXPECTED CONTAMINATED LAND FINDS MANAGEMENT 10
 4.1 Unexpected Contamination Management..... 10
 4.2 Roles and Responsibilities 11
 4.3 Project Inductions..... 12
 4.4 Unexpected Finds Procedure 13
5 MONITORING AND INSPECTIONS 15
6 RECORD KEEPING AND REPORTING 15
 6.1 Record Keeping..... 15
 6.2 Reporting..... 16
ATTACHMENT 1 UNEXPECTED FINDS PROCEDURE FLOWCHART 17

LIST OF TABLES

Table 1 – Emergency and Key Contacts 4
Table 2 – Acronyms 5
Table 3 – Glossary 6
Table 4 - UFPC scope relevant to SS1-9471 and SSI-9973..... 8
Table 5 - Reference Documents 8
Table 6 - Principal Contract Details 8
Table 7 - Nacap UFPC Responsibilities 11
Table 8 - Unexpected finds procedure and Management actions/measures 13

LIST OF EMERGENCY AND KEY CONTACTS

Table 1 – Emergency and Key Contacts

Organisation/Position	Contact Details
Environment Line (EPA Pollution Hotline)	131 555 The Environment Line handles general inquiries about environmental issues and takes reports of pollution for which the EPA has regulatory responsibilities. Environment Line is a one-stop pollution and environmental incident reporting service provided by Environment and Heritage Group and EPA.
Fire and Rescue NSW	000 (for pollution incidents that present an immediate threat to human health or property) 1300 729 579 (for pollution incidents that do not present an immediate threat to human health or property)
Wollongong City Council	General Enquiries (02) 4227 7111
NSW Ports	General Enquiries 1300 922 524
Port Authority NSW	24-hour community enquiries and complaints line (02) 9296 4962 enquiries@portauthoritynsw.com.au
Port Kembla Coal Terminal	Administration (02) 4228 0288
BlueScope	Laura Davis Laura.davis@bluescopesteel.com +61 467728547
Transport for NSW	General Enquiries (02) 8202 2200
GrainCorp	Dylan Clarkson +61 409 739 697 dclarkson@graincorp.com.au

Organisation/Position	Contact Details
AIE	Andrew Petch +61 401 175 917 Andrew.petch@ausindenergy.com
Jemena	Community Feedback - 1300 081 989 Justin Anderson 0435 092 889 justin.anderson@zinfra.com.au
Nacap	Jason Heard Nacap Project Manager j.heard@nacap.com.au +61 488 087 393

ACRONYMS

Table 2 – Acronyms

Term	Meaning
AEC	Areas of Environmental Concern
AIE	Australian Industrial Energy
ASS	Acid Sulfate Soils
ASSMP	Acid Sulfate Soils Management Plan (Soil and Water Management Plan – Appendix G)
CEMP	Construction Environmental Management Plan
CoA	Conditions of Approval
CROW	Construction Right-of-Way
EA	Environmental Assessment
ECI	Early Contractor Involvement
EES	Environment Energy and Science
EMM	Environmental Management Measures

Term	Meaning
EPA	Environment Protection Agency
GIS	Geographical Information Service
HSE	Health Safety Environment
KGMS	Kembla Grange Meter Station
LECH	Land, Environment and Cultural Heritage
NSW	New South Wales
PASS	Potential Acid Sulfate Soils
PKGT	Port Kembla Gas Terminal
PKPP	Port Kembla Pipeline Project
Principal	Jemena
PM	Project Manager
RAP	Remediation Action Plan
SSI	State Significant Infrastructure
SWMP	Soil and Water Management Plan
SWMS	Safe Work Method Statements
UFPC	Unexpected Finds Procedure Contamination (This Procedure)

GLOSSARY

Table 3 – Glossary

Term	Meaning
Company/Principal	Jemena
Contractor	Nacap
Environmental Assessment	Refers to environmental assessment undertaken in accordance with the approval and subsequent Modifications of SSI 9471 and SSI 9973.

Term	Meaning
Incident	A set of circumstances that: <ul style="list-style-type: none"> > causes or threatens to cause material harm to the environment; and/or > breaches or exceeds the limits or performance measures/criteria in this approval
Project	Port Kembla Pipeline
Regulatory Requirements	Government acts and regulations that are environment specific which prescribe legal obligations encompassing the employer and contractor.
Risk	Effect of uncertainty on objectives. Often expressed in terms of a combination of the consequences of an event (including changes in circumstances) and the associated likelihood of occurrence [ISO Guide 73:2009, definition 1.1]
Stakeholder	Party with vested interest in the works
Third Party	Any party external to the works that has been identified as a stakeholder
Unexpected contamination find	Can be defined as any unanticipated discovery of contamination, that has not been previously assessed and recorded.

1 INTRODUCTION

1.1 Purpose and Scope

This Unexpected Contaminated Land Finds Procedure (UFPC) supports the purpose and objectives outlined in the Construction Environmental Management Plan (CEMP) GAS-599-PA-EV-001 and the Soil and Water Management Sub-plan (SWMP) GAS-599-PA-EV-007 and is applicable for project based construction activities to ensure that all reasonable and practical measures are undertaken to minimise the potential for environmental harm and impacts to human health.

This UFPC is an Appendix of the SWMP and has been prepared to satisfy the requirements of both SSI 9471 and SSI 9973 including the staging of works as described in Section 1 of the CEMP and as presented in the table below.

Table 4 - UFPC scope relevant to SSI-9471 and SSI-9973

Infrastructure Approval	Post Consent Stage	Description of Works	Segment of Works As detailed in Sect 1.4 and Figure 1
SSI-9471	Stage 3	Pipeline construction from PKGT to KGMS	Segment 1.1
SSI-9973	Stage 1		Segment 1.2
			Segment 2

1.2 References

The following are principal documents referenced in this document:

Table 5 - Reference Documents

Document No.	Title of Document
GAS-554-AC-PM-001	SSI 9471 - Port Kembla Gas Terminal - Infrastructure Approval
GAS-556-AC-PM-001	SSI 9973 - Port Kembla Lateral Looping Pipeline – Infrastructure Approval including Modification 2
GAS-556-SP-PL-007	Construction Specification
GAS-551-SW-PL-001	Pipeline Construction Scope of Work
GAS-599-PA-HSE-004	Environmental Management Plan
GAS-554-RP-GI-002	Geotechnical and Contamination Investigation Interim Report
GAS-556-RP-GI-001	Geotechnical and Contamination Investigation Report
	AIE PKGT Environmental Impact Statement (GHD) 2018
GAS-599-RP-RA-007	Jemena Eastern Gas Pipeline Looping Modification Report (Coffey) 2020
	AIE PKGT Contaminated Spoil Protocol Stage 2A Marine Berth Construction and Onshore Receiving Facilities (GHD) 2021

1.3 Principal Contractor Details

Table 6 - Principal Contract Details

Nacap Details

Business name:	Nacap Pty Ltd
Address:	Ground Floor, 599 Doncaster Road, Doncaster Victoria 3108
ABN:	33 006 306 994
Main phone number:	03 8848 1888
Contact person:	Jason Heard Nacap Project Manager
Contact mobile:	+61 488 087 393
Contact email:	j.heard@nacap.com.au

1.4 Environmental Management System Overview

The environmental management system overview is described in Section 4.1 of the CEMP. This UFPC and SWMP used together with the CEMP, and subordinate project documents, procedures, resources, and practices will inform and guide Nacap personnel and subcontractors to ensure that all reasonable and practical measures are taken to manage contamination risks for the Project.

2 ENVIRONMENTAL PLANNING AND GOVERNANCE

The legislation, Conditions of Approval (CoA) and Environmental Management Measures (EMMs) relevant to this UFPC are outlined in Section 2 of the SWMP GAS-599-PA-EV-007.

3 EXISTING ENVIRONMENT

The existing Project environment is outlined in Section 3 of the SWMP GAS-599-PA-EV-007.

In relation to Section 3 of the SWMP, Contamination and Acid Sulfate Soils, the following was identified based on the Project Environmental Assessment (EA):

3.1 Contamination

A high-level assessment for contamination was undertaken during the EA and determined that no widespread or gross contamination was found, however there is considered to be a moderate potential for contamination based upon the nature of the fill material and potentially contaminating activities across the pipeline alignment associated with or resulting from surrounding industry.

The pipeline alignment through the Port area is within areas of highest concern. The project EA identified four areas of environmental concern (AEC) within the Port:

- > AEC 1 - Fill materials along the entire pipeline alignment including dredged materials, coal and coal by-product, steel production by-product (slag) and possible building demolition materials
- > AEC 2 - Spills and surface application of fuels along the entire pipeline alignment, oils and other chemicals associated with current and former industrial land uses
- > AEC 3 - Historical impacts associated with former nightsoil depot within PKCT, and
- > AEC 4 - Current and historical impacts associated with use of land adjacent to the alignment as workshops and fuel depots.

The remaining works outside the Port are generally within land used by or in proximity of Port associated industries where there may be a risk of unexpected finds along the alignment being encountered. Potential sources of contamination (areas of environmental concern) were identified along the pipeline alignment outside of the Port being:

- > Fly-tipped waste (including suspected bonded and friable asbestos containing material)
- > Uncontrolled fill
- > An infilled drainage channel
- > Previously demolished buildings
- > Stockpiles of unknown origin, and
- > Groundwater at 243A Princes Highway, Unanderra.

3.2 Acid Sulfate Soils

Acid Sulfate Soils (ASS) are naturally occurring soils containing iron sulphides which on exposure to air, oxidise and create sulfuric acid. Disturbance of ASS and/or Potential Acid Sulfate Soils (PASS) can result in adverse impacts on surface and groundwater quality, flora and fauna and their habitats.

The project environmental assessment (EA) identified that ASS was found to occur in natural estuarine sediments particularly where dark grey and green clays are observed. Estuarine sediments exist within estuarine areas within the Port area and are mapped as high probability of ASS. The pipeline alignment may intercept estuarine sediments during works associated with crossing of Gurungaty Waterway, and Allans Creek. Unexpected finds along the alignment may also be encountered.

Outside the Port area there were two areas within the alignment mapped as being Class 5 for acid sulfate soils:

- > Approximately 550 m extending west from Five Islands Road, and
- > The remaining 1.5km of the alignment at Kembla Grange.

Whilst Class 5 Acid sulfate soils do not typically contain acid sulfate soils, they are located within 500m of highly probable acid sulfate soils on adjacent land.

4 UNEXPECTED CONTAMINATED LAND FINDS MANAGEMENT

4.1 Unexpected Contamination Management

Nacap is responsible for management of unexpected contamination during pipeline construction and ensuring compliance with all applicable legislation for the minimisation of environmental harm and protection of human health.

The preferred management approach for known contamination sites is avoidance. During construction the process for avoidance will be achieved as follows:

- > The pipeline alignment and all associated infrastructure will be located to ensure all known sites are avoided with sufficient buffer to enable the implementation adequate delineation and protection from all aspects of the works.
- > Preparation of Environmental Control Plans (ECPs) will be undertaken in advance of construction. ECPs will outline the location of all known contamination sites identified in the EA that may be encountered by pipeline construction works and provision of required protective measures and details of specific buffer distances to demonstrate avoidance
- > Ongoing review, update and communication of any changes to the Project contamination assessment and register of known contamination sites in advance of construction commencement

- > Update or develop Environmental Control Plans as required upon detection of new sites of contamination or as outlined in any remediation works plans developed in advance of construction
- > Identification, protection and establishment of separation buffers for known contamination sites during works set out and establishment, and
- > Development and implementation of contingency measures including an unexpected contamination land finds procedure.

Contamination discovered as unexpected finds during construction will be managed in accordance with the unexpected finds procedure as described in Section 4.4 and Attachment 1.

Nacap will support Jemena throughout construction and provide support for ongoing consultation with landholders and stakeholders to ensure sites of known contamination are avoided and where avoidance cannot be achieved, implement appropriate management measures to minimise harm and comply with the relevant legislation and project approvals.

4.2 Roles and Responsibilities

An Organisation Chart will be developed prior to the commencement of construction and can be found in GAS-599-RC-AD-001. Refer to Appendix A of Project Management Plan (GAS-599-PA-PM-015) for Organisation Chart for ECI Phase. Position descriptions describe the responsibilities specific to positions on the Project.

Table 7 below provides a summary of Nacap UFPC responsibilities for relevant roles.

Table 7 - Nacap UFPC Responsibilities

Role	Responsibilities
Project Director (Management Representative)	<ul style="list-style-type: none"> > The Project Director provides environmental leadership and ensures that adequate, competent and experienced resources are provided and supported in the implementation of the CEMP and this UFPC.
Project Manager	<ul style="list-style-type: none"> > Provide support and guide in the implementation of this UFPC and associated controls > Provide management and leadership in the implementation of this UFPC > Ensure adequate resources are provided for implementing and maintaining environmental controls and mitigation measures in relation to contamination. > Take action including the stopping of work in response to natural events and activities which may impact on sites of known contamination or compromise the performance objectives, standards and commitments contained in the CEMP and this UFPC, and > Take action in the event of an environmental emergency and allocate the required resources to minimise environmental impact and harm resulting from contamination.
Lands, Environment and Cultural Heritage (LECH) Manager	<ul style="list-style-type: none"> > Provide support and guide the implementation of this UFPC and associated controls > Provide environmental input and support to construction and associated methodologies

Role	Responsibilities
	<ul style="list-style-type: none"> > Support and guide site environmental incident investigation and reporting, and > Review internal and external project audits and coordinate the implementation of audit recommendations.
Specialist Consultants	<ul style="list-style-type: none"> > Providing assessment and interpretation of contamination management and unexpected finds as required > Undertaking site assessments in support of construction works as required, and > Providing support to incident investigation and reporting as required.
Environment Advisor	<ul style="list-style-type: none"> > Provide and coordinate monitoring, inspections and audits of works > Provide and coordinate site-based training preparation and delivery > Routine record keeping and reporting in support of commitments in this UFPC > Reporting of hazards and incidents and implementing any rectification measures, and > Provide site based environmental incident investigation and reporting and corrective action management.
Project Supervisors	<ul style="list-style-type: none"> > Provide leadership for the implementation of commitments contained in this UFPC, and > Reporting of hazards and incidents and implementing any rectification measures.
Subcontractors	<ul style="list-style-type: none"> > Subcontractors engaged to perform works on behalf of Nacap will operate in accordance with all applicable legislation, Nacap procedures and this UFPC, and > Subcontractors are required to report all incidents to their Nacap Supervisor immediately.
All Project Personnel and Visitors	<ul style="list-style-type: none"> > All Project personnel and visitors will uphold a general environmental duty to take all reasonable and practical measures to ensure that the activities on the whole site do not cause or may cause environmental harm and impacts to human health.

4.3 Project Inductions

All construction personnel and subcontractors are required to undertake a Project induction which will incorporate information on soils and water management specific to the project and field of operations and shall include the following:

- > Environmental protection Legislation
- > Roles and Responsibilities for soil, water and unexpected finds management
- > Information on the location of existing soils and water sensitivities, and sites of known contamination in proximity to the works

- > Information relating to the identification of soil contamination – such as staining, odours, a marked / abrupt change in soil colour, soils with an oily feel or appearance, a slick / sheen on seepage or ponded water, buried waste products or other physical evidence, or patches of dead / stressed vegetation
- > The requirement to immediately report all soil contamination, both pre-existing soil contamination encountered during project activities and incidents resulting in project-generated soil contamination.
- > Mitigation management measures including erosion and sediment controls, storage of hydrocarbons and chemicals, waste, containment and spill management
- > Protocols for responding to unexpected finds of contamination
- > Incident reporting and record keeping.

A register attendance at all inductions will be maintained. A register attendance at all inductions will be maintained

4.4 Unexpected Finds Procedure

The following Unexpected Finds Procedure will be implemented in the event that any unexpected contamination is discovered during the conduct of activities associated with pipeline construction works.

Table 8 - Unexpected finds procedure and Management actions/measures

No	Action
Pre-Construction	
C01	All personnel will undertake the Project induction as described above.
C02	All construction personnel and subcontractors will participate in Safe Work Method Statement (SWMS) development that will include information on environmental sensitivities and specific management measures for specific construction activities.
C03	Environmental Control Plan (where required) with locations of all known contamination within the Project activity area is to be located at site notice board(s) and attached to the authority to commence construction (Form 2). Environment Control Plan(s) will also be communicated at daily pre-starts and weekly toolboxes as required or when works are planned in proximity to known sites of contamination.
C04	<p>Prior to project works the Project Manager or delegate shall:</p> <ul style="list-style-type: none"> > Verify all sites of known or potential contamination > Ensure completion of delineation and establishment of the approved work areas and No Go Zones etc. using flagging/markers/fencing and signage > Ensure notification of specific access or approval conditions, environmental sensitivities and all identified No Go Zones and other significant information is contained in the authority to commence works (Form 2), and > Ensure establishment of photo points and capture pre-disturbance photo records of all known contamination sites.
Construction	
C05	The approved disturbance area established as the final alignment and /or site boundaries, approved accesses and environmental “No Go” zones will be surveyed and clearly marked on-ground or through the use of tape or barrier fencing and signposting to define the works area and prevent the inadvertent disturbance or access to unauthorised areas beyond the approved boundaries. Surveys and peg-out will be based on digital data as per the Project final layout survey.
C06	Make use of existing disturbance for project layout as far as practicable, including access routes and other ancillary workspaces; negotiate with third parties for use of existing disturbed areas where necessary.
C07	All construction activities will be confined to the established and delineated approved works area and construction access tracks / roads. In doing so avoid unnecessary disturbance to areas that may yield contamination.
C08	In the event of a contamination unexpected find during works, cease the work activity in proximity to the find immediately and notify the Supervisor.
C09	Immediately contact the environmental advisor and assess the likelihood of contamination.
C10	<p>The presence of potentially contaminated material can be detected where material is uncovered which displays some or all of these characteristics:</p> <ul style="list-style-type: none"> > Unusual odour from soils that are not detected in other similar areas > Discolouration or staining of soil or rock > Seepage of unusual liquids from soil or rock > Unusual odours, sheen or colour on groundwater and/or surface water > Unusual metal objects

No	Action
	<ul style="list-style-type: none"> > Unexpected underground storage tanks, buried drums or machinery etc. > Presence of waste or rubbish above or below ground > Potential asbestos containing material
C11	Where these factors are identified and following consultation and confirmation from the environmental advisor, the material is considered to be possibly contaminated – progress the procedure and actions from C13 below.
C12	Should the environmental advisor assess the material as not being an unexpected find, continue works and monitoring for further unexpected finds.
C13	Establish a 'no-go zone' around the item commensurate with the size of the find providing a minimum 5m buffer around the find. Use appropriate protection measures to isolate and protect the site. Inform all site personnel that the 'no-go zone' has been established and works cannot continue in immediate proximity.
C14	In advance of any works undertake a risk assessment to determine appropriate health and safety controls and PPE. Install appropriate containment, stormwater/drainage and sediment controls to protect the site. Contaminated material will be stockpiled and stored on hardstand or lined areas and segregated from uncontaminated material to prevent cross-contamination. Provide any additional controls to ensure the site does not present an unacceptable health and safety. hazard to personnel, the public and adjoining land use.
C15	Notify the EPA Environment Line 131 555 where there is environmental harm or a pollution event has occurred. The Environment Line is a one-stop pollution and environmental incident reporting service provided by Environment and Heritage Group and EPA. Undertake any subsequent incident reporting in accordance with Section 7 of the CEMP.
C16	If sufficient work space and if safe to do, relocate any plant, equipment and vehicles adequately ahead of the find site.
C17	Inspect, document and record the item including photographs and coordinates of the find site. Observe and record the following details of the unexpected contamination find: <ul style="list-style-type: none"> > Location of the potential contamination > Visual appearance > Odour (if any) > Depth > Surrounding material and works being undertaken at the time of discovering the material
C18	Do not touch or disturb the item/ materials.
C19	At the direction of the AIE and or Jemena Representative, the LECH Manager is to obtain assistance from a suitably qualified and experienced contaminated land consultant in identifying the potential hazard to human health or environment. Undertake any sampling and laboratory analysis of materials that may be required in accordance with relevant guidelines. Support AIE and or Jemena to progress any additional assessment and notification to the EPA as determined in consultation with the contaminated land consultant..
C20	Undertake any temporary remediation or amended works as directed to ensure the site does not present an unacceptable health and safety hazard.
C21	Material not approved for backfill or surplus to project requirements will be classified in accordance with the NSW EPA Waste Classification requirements and handled and transported by a licenced transporter to a licenced facility for disposal. Refer also to the Waste Management Plan (WMP) (GAS-599-PA-EV-008) Disposal of materials will be recorded in the Disposals Register (WMP Appendix B). On site movement of materials will be recorded in the Materials Tracking Register (WMP Appendix C).
C22	Recommence works at sites subject to any site validation and approval by AIE and or Jemena Representative.
C23	Asbestos An unexpected asbestos find occurs when Asbestos Containing Materials (ACM), not associated with a known site of contamination is found on site. In the event of an unexpected asbestos find, the below steps are to be followed:
C24	Ensure the soil and potential asbestos remain damp with dust suppression or securely covered where water cannot be accessed. If material is to be left over night, exposed area is to be securely covered with geofabric.
C25	If required and at the direction of the AIE and or Jemena representative arrange for testing of the suspected ACM and arrange for an occupational hygienist to undertake monitoring of the area as required.
C26	At the direction of AIE and or Jemena engage a licenced asbestos removalist to provide recommendations, treatments transport and disposal as required.
C27	A clearance certificate to be provided by an independent licenced asbestos assessor or competent person to confirm that the area safe and suitable for the re-commencement of works.
C28	Acid Sulfate Soils An unexpected ASS find may occur where specific physical characteristics such as staining and sulfurous odours associated with ASS are detected during excavations in ASS risk areas, particularly excavation of estuarine sediments within the Port. If suspected ASS the following steps to be followed:
C29	In consultation with the AIE and or Jemena Representative modify the work to avoid the area of ASS if practicable and safe to do so.

No	Action
C30	If the excavation of potential ASS cannot be avoided undertake in situ testing to confirm ASS status and manage in accordance with the Acid Sulfate Soils Management Plan (ASSMP) Refer to the Soil and Water Management Plan Appendix G
C31	Undertake all site management in accordance with the ASSMP.
C32	Any untreated material not approved for backfill or reuse requiring to be removed and disposed off-site will be classified in accordance with the NSW EPA Waste Classification requirements and handled and transported by a licenced transporter to a licenced facility for disposal.
C33	RAP Where the reporting of an unexpected find determines that remediation is required a Remediation Action Plan (RAP) will be prepared by a suitably qualified contaminated land consultant and be provided to the Project nominated site auditor for review.
C34	RAP actions will be implemented as directed by AIE and Jemena Representative
C35	Should contaminated material require offsite disposal refer to the Waste Management Plan (WMP) for guidance on management, handling, waste classification, disposal and tracking requirements. Disposal of materials will be recorded in the Disposals Register (WMP Appendix B). On site movement of materials will be recorded in the Materials Tracking Register (WMP Appendix C).
C36	Recommence works at sites subject of RAP once validation of contaminated land has been confirmed in accordance with any RAP.

5 MONITORING AND INSPECTIONS

The Nacap LECH Manager or delegate shall coordinate inspections and monitoring of works and actions to support the unexpected find and isolation and protection of the unexpected finds site(s).

Site inspections will be recorded (along with actions and issues observed) and actioned appropriately within agreed timeframes. Inspections will be recorded as part of Environmental Inspection Checklist.

Non-compliance and incident reporting will be implemented in accordance with Section 7 of the CEMP. Any stakeholder / landholder communications and or complaints will be managed as per Section 5.4 of the CEMP and notified to the Project Manager and appropriate corrective actions implemented including a review of work practices and protective measures to ensure no repeat occurrences.

6 RECORD KEEPING AND REPORTING

6.1 Record Keeping

The Project shall maintain a documentation and record system in support of the CEMP and this UFPC including Project HSE reporting requirements to enable review and auditing of environmental management systems and procedures.

The following records are expected to be generated in relation unexpected finds management and monitoring:

- > Visual monitoring and environmental inspection records
- > Landowner and Stakeholder discussion records
- > Induction, training and awareness records
- > Unexpected finds site and construction activity specific records and registers
- > Disturbance records
- > Disposals Register
- > Materials Tracking Register

- > Reporting of Environmental Incident, non-conformances and corrective actions
- > Audit reports, and
- > Complaints.

Records will include at a minimum:

- > Incident reports in relation to unexpected finds
- > Photographs
- > GIS data
- > Environmental Inspection Reports.
- > Landowner and Stakeholder discussion records

6.2 Reporting

Daily, Weekly, Monthly and Annual Reporting will include information on relevant unexpected finds data and commentary as generated in support of unexpected finds, incident and complaint management, regulatory and contractual requirements.

ATTACHMENT 1 UNEXPECTED FINDS PROCEDURE FLOWCHART

Figure 1 Unexpected Finds Procedure – Contamination Flowchart

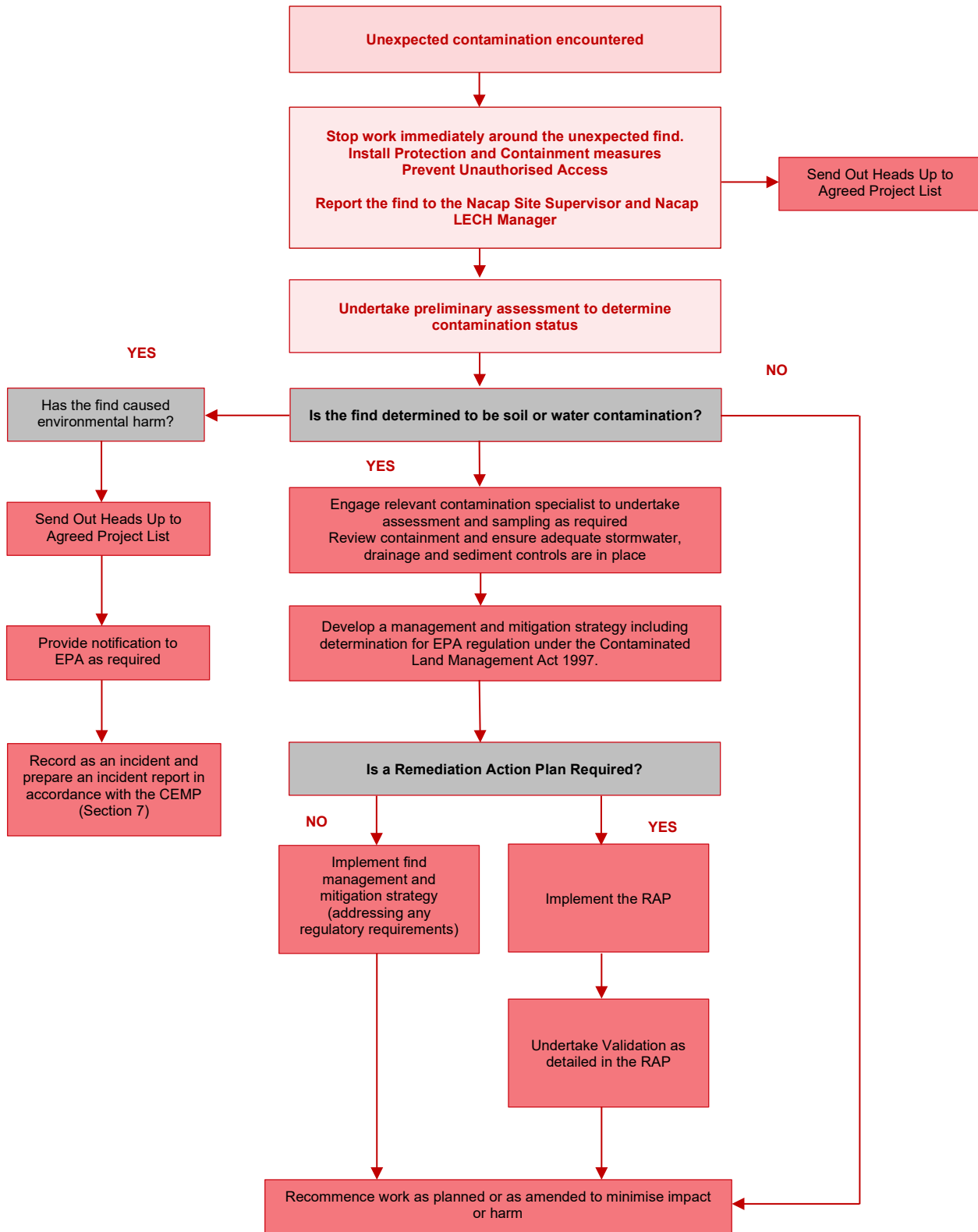

APPENDIXE UNEXPECTED HERITAGE & HUMAN REMAINS PROCEDURE

Jemena

Port Kembla Pipeline Project

UNEXPECTED HERITAGE FINDS & HUMAN REMAINS PROCEDURE

Document No.: GAS-599-PR-CH-001 | Revision 4

4	Issued for Use	BRO	RPO	BPH	JHE	30-NOV-2022
3	Issued for Use	BRO	RPO	BPH	JHE	21-NOV-2022
2	Issued for Use	BRO	RPO	BPH	JHE	2-Nov-2022
1	Issued for Use	BRO	BPH	NFU	BKE	1-AUG-2022
0	Issued for Use	BRO	ZFR	NFU	JHE	1 -JUNE-2022
A	Issued for Review	BRO	ZFR	NFU	JHE	6-MAY-2022
Rev	Description	By	Checked	QA	Nacap Approved	Date

REVISION HISTORY

This table describes changes made for numerical revisions after Rev 0

Date	Rev	By	Description
1/8/2022	1	BRO	Update of Emergency Contact details for Approvals consultation
2/11/2022	2	BRO	Updated in response to DPE review
18/11/2022	3	BRO	Table 4 updated
30/11/22	4	BRO	Minor update following DPE Review

CONTENTS

ACRONYMS..... 6

GLOSSARY..... 7

1 INTRODUCTION 8

1.1 Purpose and Scope..... 8

 1.2 References..... 9

 1.3 Principal Contractor Details..... 9

1.4 Consultation..... 9

 1.5 Environmental Management System Overview..... 10

2 ENVIRONMENTAL PLANNING AND GOVERNANCE 10

3 EXISTING ENVIRONMENT 10

 3.1 Historical Heritage..... 10

 3.2 Aboriginal cultural heritage..... 10

4 UNEXPECTED HERITAGE FINDS AND HUMAN REMAINS MANAGEMENT..... 11

 4.1 Heritage Management 11

 4.2 Heritage Management Guidelines..... 11

 4.3 Roles and Responsibilities 11

 4.4 Project Inductions..... 13

 4.5 Unexpected Heritage Items and Objects..... 13

 Aboriginal Objects 14

 Non-Aboriginal Heritage Items..... 14

 Human Remains..... 14

 4.6 Unexpected Finds Procedure 15

5 MONITORING AND INSPECTIONS 16

6 RECORD KEEPING AND REPORTING 16

 6.1 Record Keeping..... 16

 6.2 Reporting..... 17

 Environmental Incident Reporting 17

APPENDIX A CONSULTATION RECORD..... 18

APPENDIX B UNEXPECTED FINDS PROCEDURE FLOWCHART..... 19

LIST OF TABLES

Table 1 – Emergency and Key Contacts..... 5

Table 2 – Acronyms 6

Table 3 – Glossary..... 7

Table 4 - UFPH scope relevant to SS1-9471 and SSI-9973..... 8

Table 5 - Reference Documents 9

Table 6 - Principal Contract Details 9

Table 7 - Nacap UFPH Responsibilities 12

Table 8 - Unexpected finds procedure and Management actions/measures..... 15

LIST OF EMERGENCY AND KEY CONTACTS

Table 1 – Emergency and Key Contacts

Organisation/Position	Contact Details
Environment Line (EPA Pollution Hotline)	131 555 The Environment Line handles general inquiries about environmental issues and takes reports of pollution for which the EPA has regulatory responsibilities. Environment Line is a one-stop pollution and environmental incident reporting service provided by Environment and Heritage Group and EPA.
Fire and Rescue NSW	000 (for pollution incidents that present an immediate threat to human health or property) 1300 729 579 (for pollution incidents that do not present an immediate threat to human health or property)
Wollongong City Council	General Enquiries (02) 4227 7111
NSW Ports	General Enquiries 1300 922 524
Port Authority NSW	24-hour community enquiries and complaints line (02) 9296 4962 enquiries@portauthoritynsw.com.au
Port Kembla Coal Terminal	Administration (02) 4228 0288
BlueScope	Laura Davis Laura.davis@bluescopesteel.com +61 467728547
Transport for NSW	General Enquiries (02) 8202 2200
GrainCorp	Dylan Clarkson +61 409 739 697 dclarkson@graincorp.com.au
AIE	Andrew Petch +61 401 175 917 Andrew.petch@ausindenergy.com

Organisation/Position	Contact Details
Jemena	Community Feedback - 1300 081 989 Justin Anderson 0435 092 889 justin.anderson@zinfra.com.au
Nacap	Jason Heard Nacap Project Manager j.heard@nacap.com.au +61 488 087 393

ACRONYMS

Table 2 – Acronyms

Term	Meaning
AHIMS	Aboriginal Heritage Information Management System
AIE	Australian Industrial Energy
BCD	Biodiversity Conservation Division
CEMP	Construction Environmental Management Plan
CoA	Conditions of Approval
CROW	Construction Right-of-Way
EA	Environmental Assessment
ECI	Early Contractor Involvement
EES	Environment Energy and Science
EIS	Environmental Impact Statement
EMM	Environmental Management Measures
EPA	Environment Protection Agency
GIS	Geographical Information Service
HSE	Health Safety Environment

Term	Meaning
ILALC	Illawarra Local Aboriginal Land Council
KGMS	Kembla Grange Meter Station
LECH	Land, Environment and Cultural Heritage
NSW	New South Wales
NSW PW Act	NSW Parks and Wildlife Act 1974
PKGT	Port Kembla Gas Terminal
PKPP	Port Kembla Pipeline Project
Principal	Jemena
PM	Project Manager
RAP	Registered Aboriginal Party
SSI	State Significant Infrastructure
SWMP	Soil and Water Management Plan
SWMS	Safe Work Method Statements
UFPH	Unexpected Finds Procedure Heritage (This Procedure)

GLOSSARY

Table 3 – Glossary

Term	Meaning
Company/Principal	Jemena
Contractor	Nacap
Environmental Assessment	Includes the following EIS and Modification Reports: <ul style="list-style-type: none"> > Port Kembla Gas Terminal EIS and Modifications 1, 2 and 3, and > Eastern Gas Pipeline EIS and Modifications 1 and 2.

Term	Meaning
Incident	A set of circumstances that: > causes or threatens to cause material harm to the environment; and/or > breaches or exceeds the limits or performance measures/criteria in this approval
Project	Port Kembla Pipeline
Regulatory Requirements	Government acts and regulations that are environment specific which prescribe legal obligations encompassing the employer and contractor.
Risk	Effect of uncertainty on objectives. Often expressed in terms of a combination of the consequences of an event (including changes in circumstances) and the associated likelihood of occurrence [ISO Guide 73:2009, definition 1.1]
Stakeholder	Party with vested interest in the works
Third Party	Any party external to the works that has been identified as a stakeholder
Unexpected heritage find	Can be defined as any unanticipated archaeological discovery, that has not been previously assessed or is not covered by an existing excavation or harm permit, and that has potential heritage value.

1 INTRODUCTION

1.1 Purpose and Scope

This Unexpected Heritage Finds and Human Remains Procedure (UFPH) supports the purpose and objectives outlined in the Construction Environmental Management Plan (CEMP) GAS-599-PA-EV-001 and the Soil and Water Management Sub-plan (SWMP) GAS-599-PA-EV-007 and is applicable for project based construction activities to ensure that all reasonable and practical measures are undertaken to minimise the potential for harm to Heritage and sites of archaeological significance including human remains and burial sites and related impacts.

This UFPH is an Appendix of the SWMP and has been prepared to satisfy the requirements of both SSI 9471 and SSI 9973 including the staging of works as described in Section 1 of the CEMP and as presented in the table below.

Table 4 - UFPH scope relevant to SS1-9471 and SSI-9973

Infrastructure Approval	Post Consent Stage	Description of Works	Segment of Works As detailed in Sect 1.4 and Figure 1
SSI-9471	Stage 3	Pipeline construction from PKGT to KGMS	Segment 1.1
SSI-9973	Stage 1		Segment 1.2
			Segment 2

1.2 References

The following are principal documents referenced in this document:

Table 5 - Reference Documents

Document No.	Title of Document
GAS-554-AC-PM-001	SSI 9471 - Port Kembla Gas Terminal - Infrastructure Approval
GAS-556-AC-PM-001	SSI 9973 - Port Kembla Lateral Looping Pipeline – Infrastructure Approval including Modification 2
GAS-556-SP-PL-007	Construction Specification
GAS-551-SW-PL-001	Pipeline Construction Scope of Work
GAS-599- PA-HSE-004	Environmental Management Plan
	AIE PKGT Environmental Impact Statement (GHD) 2018
	Jemena Eastern Gas Pipeline Looping Modification Report (Coffey) 2020
	AIE PKGT Heritage Unexpected Finds Protocol - Early Enabling Works (GHD May 2021)

1.3 Principal Contractor Details

Table 6 - Principal Contract Details

Nacap Details	
Business name:	Nacap Pty Ltd
Address:	Ground Floor, 599 Doncaster Road, Doncaster Victoria 3108
ABN:	33 006 306 994
Main phone number:	03 8848 1888
Contact person:	Jason Heard Nacap Project Manager
Contact mobile:	+61 488 087 393
Contact email:	j.heard@nacap.com.au

1.4 Consultation

Consultation on this UFPH has been undertaken with the following stakeholders:

- > Transport for NSW (TfNSW)
- > Wollongong City Council
- > Sydney Trains
- > BCD and Heritage, and
- > Illawarra Local Aboriginal Land Council.

Comments and feedback received during consultation have been incorporated into the Plan where relevant before being submitted to the DPE for approval.

Details of the Consultation associated with this Plan are presented in Appendix A

1.5 Environmental Management System Overview

The environmental management system overview is described in Section 4.1 of the CEMP. This UFPH and SWMP used together with the CEMP, and subordinate project documents, procedures, resources, and practices will inform and guide Nacap personnel and subcontractors to ensure that all reasonable and practical measures are taken to manage Heritage risks for the Project.

2 ENVIRONMENTAL PLANNING AND GOVERNANCE

The legislation, Conditions of Approval (CoA) and Environmental Management Measures (EMMs) relevant to this UFPH are outlined in Section 2 of the SWMP GAS-599-PA-EV-007.

3 EXISTING ENVIRONMENT

The existing Project environment is outlined in Section 3 of the SWMP GAS-599-PA-EV-007.

In relation to Section 3, Heritage of the SWMP the following was identified based on the Project Environmental Assessment (EA):

3.1 Historical Heritage

During construction of the pipeline there is potential for historical features and archaeological deposits associated with early settlement and previous pastoral activities to survive in limited areas. Mapping and aerial photographs assessed during the EA indicate that the pipeline alignment traverses an area largely rural in nature, prior to industrialisation, with built features largely relating to homesteads and outbuildings. While built features appear to have largely been removed, historical features with the most likely potential to be present include:

- > remains of early private roads
- > house and outbuilding foundations
- > rural domestic rubbish dumps and associated archaeological deposits.

Subsequent investigation including ground penetrating radar during development of the pipeline alignment also identified potential for buried urns associated with the Wollongong Memorial Gardens to be in proximity to the pipeline alignment. There are no formal records or indicative surface markers to delineate their location.

Whilst the pipeline alignment has been developed to avoid known areas of heritage, there remains potential during excavation works to uncover heritage as unexpected finds.

3.2 Aboriginal cultural heritage

An extensive search of the Aboriginal Heritage Information Management System (AHIMS) was undertaken during the EA and identified one Aboriginal site within the assessment area, BSS-OS-1 (52-2-3618). 52-2-3618 is an open camp site recorded in 2008 and consists of two flaked stone artefacts likely to have been introduced with material used in road construction in an area of disturbance. The pipeline alignment has been developed to avoid this site.

The remaining areas of the alignment were assessed as being highly disturbed and having a low likelihood of archaeological potential due to the landforms, soil types and disturbance.

There remains however, potential risk for excavation works associated with the construction of the pipeline to expose unexpected archaeological finds including Aboriginal ancestral remains.

4 UNEXPECTED HERITAGE FINDS AND HUMAN REMAINS MANAGEMENT

4.1 Heritage Management

Nacap is responsible for Heritage management during pipeline construction and ensuring compliance with all applicable legislation for the protection and conservation of Heritage.

The preferred management approach for known heritage sites is avoidance. During construction the process for avoidance will be achieved as follows:

- > The pipeline alignment and all associated infrastructure will be located to ensure all known sites are avoided with sufficient buffer to enable the implementation adequate delineation and protection from all aspects of the works.
- > Preparation of Heritage Control Plans as required to detail the location of all known heritage sites and required protective measures and details of specific buffer distances to demonstrate avoidance
- > Ongoing review, update and communication of any changes to the Project Heritage assessment and register of known heritage sites in advance of construction commencement
- > Update or develop Heritage Control Plans as required upon detection of new sites of significance
- > Development of a Project culture in which the importance of heritage values is recognised and respected
- > Identification, protection and establishment of separation buffers for known heritage sites during works set out and establishment, and
- > Development and implementation of contingency measures including an unexpected heritage finds and human remains procedure.

Heritage sites and materials including human remains that are discovered as unexpected finds during construction will be managed in accordance with the unexpected finds procedure as described in Section 4.5 and Appendix B.

Nacap will support Jemena throughout construction and provide support for ongoing consultation with local traditional owners and registered parties and landholders to ensure all heritage sites are avoided.

4.2 Heritage Management Guidelines

The following Heritage guidelines and codes of practice are relevant to this UFPH:

- > Department of Environment, Climate Change and Water 2010, Code of Practice for the Archaeological Investigation of Aboriginal Objects in NSW
- > Heritage Branch of the Department of Planning, 2009, Assessing Significance for Historical Archaeological Sites and 'Relics'
- > Department of Environment, Climate Change and Water 2010, Aboriginal Cultural Heritage Consultation Requirements for Proponents, and
- > Department of Environment, Climate Change and Water 2010. Due Diligence Code of Practice for the Protection of Aboriginal Objects in New South Wales

4.3 Roles and Responsibilities

An Organisation Chart will be developed prior to the commencement of construction and can be found in GAS-599-RC-AD-001. Refer to Appendix A of Project Management Plan (GAS-599-PA-PM-015) for Organisation Chart for ECI Phase. Position descriptions describe the responsibilities specific to positions on the Project.

Table 7 below provides a summary of Nacap UFPH responsibilities for relevant roles.

Table 7 - Nacap UFPH Responsibilities

Role	Responsibilities
Project Director (Management Representative)	<p>The Project Director provides environmental leadership and ensures that adequate, competent and experienced resources are provided and supported in the implementation of the CEMP and this UFPH.</p>
Project Manager	<ul style="list-style-type: none"> > Provide support and guide in the implementation of this UFPH and associated controls > Provide management and leadership in the implementation of this UFPH > Ensure adequate resources are provided for implementing and maintaining environmental controls and mitigation measures in relation to heritage. > Take action including the stopping of work in response to natural events and activities which may impact on protection and conservation of heritage or compromise the performance objectives, standards and commitments contained in the CEMP and this UFPH, and > Take action in the event of an environmental emergency and allocate the required resources to minimise environmental impact and harm including heritage.
Lands, Environment and Cultural Heritage (LECH) Manager	<ul style="list-style-type: none"> > Provide support and guide the implementation of this UFPH and associated controls > Provide environmental input and support to construction and associated methodologies > Support and guide site environmental incident investigation and reporting, and > Review internal and external project audits and coordinate the implementation of audit recommendations.
Consultant Archaeologist	<ul style="list-style-type: none"> > Providing assessment and interpretation of heritage management and unexpected finds as required > Undertaking site assessments in support of construction works as required, and > Providing support to incident investigation and reporting as required.
Environment Advisor	<ul style="list-style-type: none"> > Provide and coordinate monitoring, inspections and audits of works > Provide and coordinate site-based training preparation and delivery > Routine record keeping and reporting in support of commitments in this UFPH > Reporting of hazards and incidents and implementing any rectification measures, and > Provide site based environmental incident investigation and reporting and corrective action management.

Role	Responsibilities
Project Supervisors	<ul style="list-style-type: none"> > Provide leadership for the implementation of commitments contained in this UFPH, and > Reporting of hazards and incidents and implementing any rectification measures.
Subcontractors	<ul style="list-style-type: none"> > Subcontractors engaged to perform works on behalf of Nacap will operate in accordance with all applicable legislation, Nacap procedures and this UFPH, and > Subcontractors are required to report all incidents to their Nacap Supervisor immediately.
All Project Personnel and Visitors	<ul style="list-style-type: none"> > All Project personnel and visitors will uphold a general environmental duty to take all reasonable and practical measures to ensure that the activities on the whole site do not cause or may cause environmental harm including heritage.

4.4 Project Inductions

All construction personnel and subcontractors are required to undertake a Project Heritage induction which will incorporate information on Heritage management specific to the project and field of operations and shall include the following:

- > Legislation and penalties for the protection of Heritage
- > Roles and Responsibilities for heritage management
- > Information on the location of existing known and potential Aboriginal and non-Aboriginal heritage and extent of protective measures including buffers (Heritage Control Plan where required)
- > Information on types of Aboriginal and non-Aboriginal heritage materials that have potential to be uncovered in the project area and field of operations
- > Avoidance strategies and heritage management measures
- > Procedures for responding to unexpected finds of Aboriginal and non-Aboriginal heritage sites, including human remains, and
- > Incident reporting and record keeping.

A register attendance at all inductions will be maintained

4.5 Unexpected Heritage Items and Objects

An ‘unexpected heritage find’ can be defined as any unanticipated archaeological discovery, that has not been previously assessed or is not covered by an existing excavation or harm permit, and that has potential heritage value.

In New South Wales, there are strict laws to protect and manage heritage objects and relics.

As a result, appropriate heritage management measures need to be implemented to minimise impacts on heritage values, ensure compliance with relevant heritage notification and other obligations, and to minimise the risk of penalties to individuals, Nacap, Jemena and AIE.

Unanticipated discoveries are categorised as either:

- > Aboriginal objects

- > Historic (non-Aboriginal) heritage items
- > Human skeletal remains

Aboriginal Objects

The National Parks and Wildlife Act 1974 (NPW Act) protects Aboriginal objects which are defined as:

- > “any deposit, object or material evidence (not being a handicraft made for sale) relating to the Aboriginal habitation of the area that comprises New South Wales, being habitation before or concurrent with (or both) the occupation of that area by persons of non-Aboriginal extraction, and includes Aboriginal remains”
- > Examples of Aboriginal objects include:
 - Stone tool artefacts
 - Shell middens
 - Axe grinding grooves
 - Pigment or engraved rock art
 - Burial sites
 - Scarred trees

Non-Aboriginal Heritage Items

The Heritage Act 1977 (Heritage Act) protects non-Aboriginal heritage items which are defined as:

- > “any deposit, artefact, object or material evidence that relates to the settlement of the area that comprises NSW, not being Aboriginal settlement; and is of State or local heritage significance”.
- > Non-Aboriginal heritage items may include:
 - Archaeological ‘relics
 - Other historic items (i.e. works, structures, buildings or movable objects)
- > Relics are archaeological items of local or state significance which may relate to past domestic, industrial or agricultural activities in NSW, and can include bottles, remnants of clothing, pottery, building materials and general refuse.

Human Remains

Human skeletal remains can be identified as either an Aboriginal object or non-Aboriginal relic depending on ancestry of the individual (Aboriginal or non-Aboriginal) and burial context (archaeological or non-archaeological).

Remains are considered to be archaeological when the time elapsed since death is suspected of being 100 years or more.

All bones must be treated as potential human skeletal remains and work around them must stop while they are protected and investigated urgently. Under the applicable legislation, the following agencies must be notified in the event of human remains being discovered:

- > NSW Police
- > NSW Coroner’s office, and
- > NSW Environment and Heritage Group

In the event that work must stop due to human remains being uncovered, works will not recommence within the area until authorised by NSW Environment and Heritage Group.

4.6 Unexpected Finds Procedure

The following Unexpected Finds Procedure will be implemented in the event that any unexpected or suspected heritage item including suspected human remains are discovered during the conduct of activities associated with pipeline construction works.

Table 8 - Unexpected finds procedure and Management actions/measures

No	Action
Pre-Construction	
H01	All personnel will undertake the Project Heritage induction as described above.
H02	Nacap will take all reasonable steps to ensure that Project personnel act and conduct themselves in a manner that is not offensive, intimidating or disrespectful and/or prejudicial to representatives of Aboriginal Parties.
H03	All construction personnel and subcontractors will participate in Safe Work Method Statement (SWMS) development that will include information on heritage sensitivities and specific management measures for specific construction activities.
H04	The Heritage Control Plan (where required) with locations of all previously recorded AHIMS items within the Project activity area is to be located at site notice board(s) and attached to the authority to commence construction (Form 2). The Heritage Control Plan will also be communicated at daily pre-starts and weekly toolboxes as required or when works are planned in proximity to known sites.
H05	<p>Prior to project works the Project Manager or delegate shall:</p> <ul style="list-style-type: none"> > Verify all sites of known or potential heritage significance > Ensure completion of delineation and establishment of the approved work areas and No Go Zones etc. using flagging/markers/fencing and signage > Ensure notification of specific access or approval conditions, heritage sensitivities and all identified Heritage No Go Zones and other significant information is contained in the authority to commence works (Form 2), and > Ensure establishment of photo points and capture pre-disturbance photo records of all known heritage sites.
Construction	
H06	The approved disturbance area established as the final alignment and /or site boundaries, approved accesses and heritage "No Go" zones will be surveyed and clearly marked on-ground or through the use of tape or barrier fencing and signposting to define the works area and prevent the inadvertent disturbance or access to unauthorised areas beyond the approved boundaries. Surveys and peg-out will be based on digital data as per the Project final layout survey and AHIMS data.
H07	Make use of existing disturbance for project layout as far as practicable, including access routes and other ancillary workspaces; negotiate with third parties for use of existing disturbed areas where necessary.
H08	<p>All construction activities will be confined to the established and delineated approved works area and construction access tracks / roads.</p> <p>In doing so avoid unnecessary disturbance to areas that may yield heritage from the landscape such as:</p> <ul style="list-style-type: none"> > Water courses > Stony outcrops, clay pans and alluvial deposits, and > Mature vegetation.
H09	In the event of a heritage unexpected find (including skeletal remains) during works, cease the work activity in proximity to the find immediately and notify the Supervisor.
H10	Establish a 'no-go zone' around the item commensurate with the size of the find providing a minimum 5m buffer around the find. Use appropriate protection measures to isolate and protect the site.
H11	Inform all site personnel that the 'no-go zone' has been established and works cannot continue in immediate proximity. Send Out Heads Up to Agreed Project List and support Jemena in providing notification to Environment and Heritage via the Environment Line 131 555. The Environment Line is a one-stop pollution and environmental incident reporting service provided by Environment and Heritage Group and EPA.
H12	If sufficient work space and if safe to do relocate any plant, equipment and vehicles adequately ahead of the find site.
H13	Inspect, document and record the item including photographs and coordinates of the find site.
H14	Where bone material is uncovered and it is obvious that the bones are human remains, advise the Supervisor of the find and support Jemena in progressing contact and provision of information to local police.
H15	Should the Police attend the site they may take command of all or part of the site.
H16	In the event that Police command the site ensure the Supervisor and the Jemena representative is informed to enable works contingency arrangements to be developed and the site is secured safely.
H17	Where human remains are likely to be Aboriginal ancestral remains there is a requirement for the Project to contact NSW Environment and Heritage.
H18	The Project will contact a qualified Aboriginal or Historical archaeologist to discuss the location and extent of the item and arrange a site inspection, if required. Preference should be given to using an archaeologist supplied by the Illawarra Local Area Land Council (ILALC) for local context or the assigned Consultant Archaeologist who completed the heritage assessments for the EIS. Provide support to Jemena along with any site discovery records including photos and spatial location where requested.

No	Action
H19	In a minority of cases, the Aboriginal or Historical archaeologist or ILALC Representative may determine from the photographs that no site inspection is required because no archaeological constraint exists for the Project (e.g., the item is not a 'relic', a 'heritage item' or an 'Aboriginal object'). Ensure all communication and advice is formally communicated. Refer all communication to the Project Manager and other nominated representatives for management of the unexpected find event.
H20	Arrange site access where requested for the Aboriginal or Historical archaeologist/Aboriginal heritage consultant to inspect the item as soon as practicable.
H21	Subject to Jemena advice following the Aboriginal or Historical archaeologist/Aboriginal heritage consultant's assessment, work may recommence with appropriate protection and buffers established.
H22	Where required and requested support Jemena to obtain and coordinate additional specialist technical advice (such as a forensic or physical anthropologist to identify skeletal remains).
H23	Where the item has been identified as a 'relic' or 'heritage item' or an 'Aboriginal object' the Aboriginal or Historical archaeologist will formally record the item.
H24	Where an Aboriginal object is recorded it will be registered on AHIMS in accordance with section 89A of the NPW Act.
H25	Should the site be registered, this will trigger the requirement for the development of management actions to protect and conserve the site to ensure that ongoing harm is minimised.
H26	Provide support to Jemena in meeting the requirements of any management actions to enable the recommencement of works or other actions to avoid the site including any Project contingency and commercial management actions as determined by the Project Management Team

Source: AIE PKGT Heritage Unexpected Finds Protocol - Early Enabling Works (GHD 2021)

5 MONITORING AND INSPECTIONS

The Nacap LECH Manager or delegate shall coordinate inspections and monitoring of works and actions to support the unexpected find and isolation and protection of the unexpected finds site(s).

Site inspections will be recorded (along with actions and issues observed) and actioned appropriately within agreed timeframes. Inspections will be recorded as part of Environmental Inspection Checklist.

Non-compliance and incident reporting will be implemented in accordance with Section 7 of the CEMP. Any stakeholder / landholder communications and or complaints will be managed as per Section 5.4 of the CEMP and notified to the Project Manager and Principal Representative and appropriate corrective actions implemented including a review of work practices and protective measures to ensure no repeat occurrences.

6 RECORD KEEPING AND REPORTING

6.1 Record Keeping

The Project shall maintain a documentation and record system in support of the CEMP and this UFPH including Project HSE reporting requirements to enable review and auditing of environmental management systems and procedures.

The following records are expected to be generated in relation unexpected finds management and monitoring:

- > Visual monitoring and environmental inspection records
- > Landowner and Stakeholder discussion records
- > Induction, training and awareness records
- > Unexpected finds site and construction activity specific records and registers
- > Disturbance records
- > Reporting of Environmental Incident, non-conformances and corrective actions
- > Audit reports, and

- > Complaints.

Records will include at a minimum:

- > Incident reports in relation to unexpected finds
- > Photographs
- > GIS data
- > Environmental Inspection Reports.
- > Landowner and Stakeholder discussion records

6.2 Reporting

Daily, Weekly, Monthly and Annual Reporting will include information on relevant unexpected finds data and commentary as generated in support of unexpected finds, incident and complaint management, regulatory and contractual requirements.

Environmental Incident Reporting

Environmental incidents will be reported in accordance with the CEMP Section 7.1.

APPENDIX A CONSULTATION RECORD

Stakeholder	Date Sent	Send Method	Due Date	Date Received	Comments
Wollongong City Council (WCC)	30/08/2022	Email	13/09/2022	10/11/2022	Completing review, however, note that the deadline has passed.
Sydney Trains	30/08/2022	Email	13/09/2022	15/09/2022	No Comments
Transport for NSW	30/08/2022	Email	13/09/2022	21/09/2022	No Comments
BCD / Heritage	25/08/2022	Email	9/09/2022	16/09/2022	No Comments
Illawarra Local Aboriginal Land Council	25/08/2022	Email	9/09/2022	-	No Response

APPENDIX B UNEXPECTED FINDS PROCEDURE FLOWCHART

Figure 1 Unexpected Finds Procedure Flowchart (1 Page)

Figure 2 Unexpected Finds (Skeletal Remains) Procedure Flowchart (1 Page)

Figure 1 Unexpected Finds Procedure Flowchart

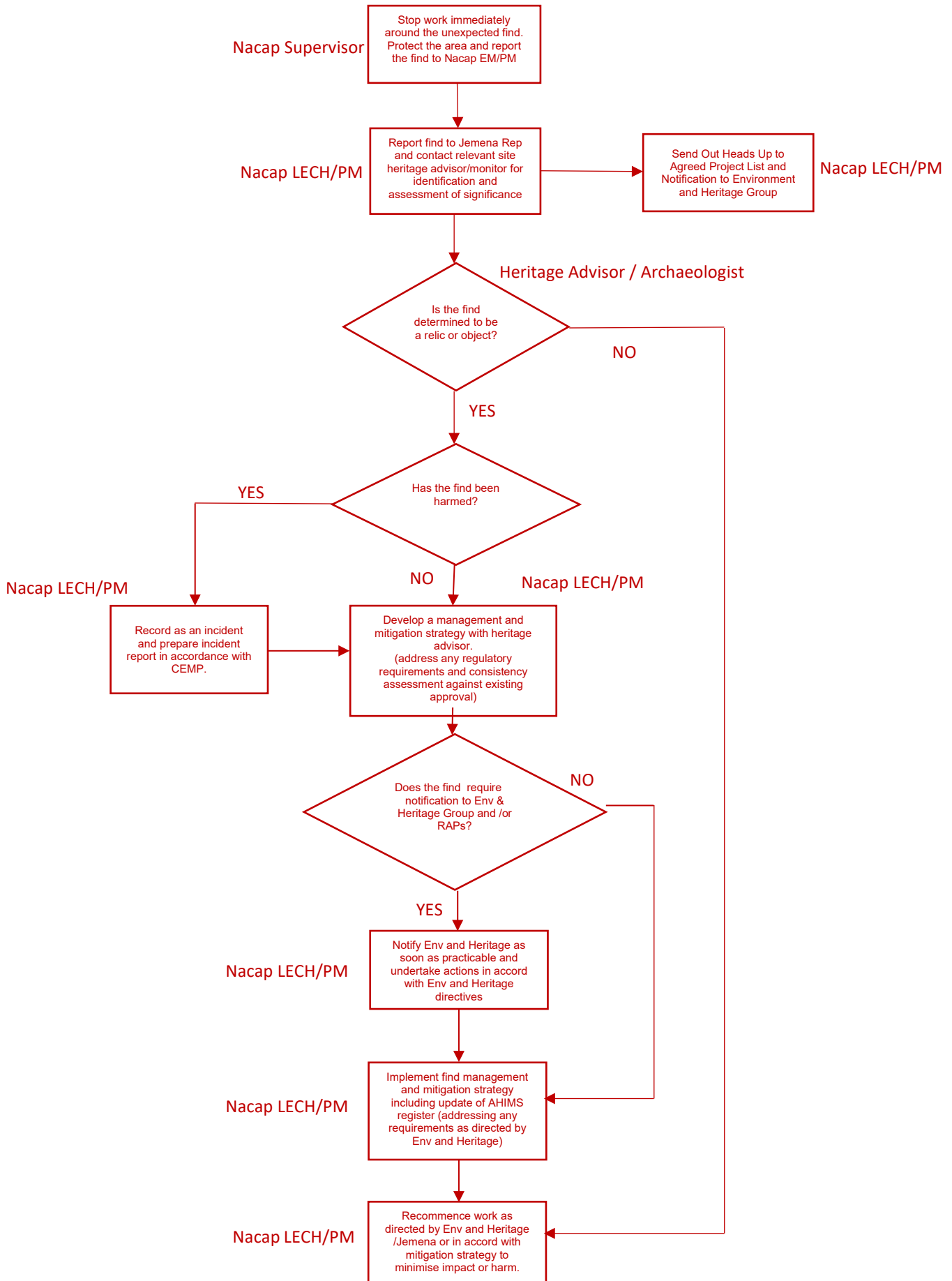
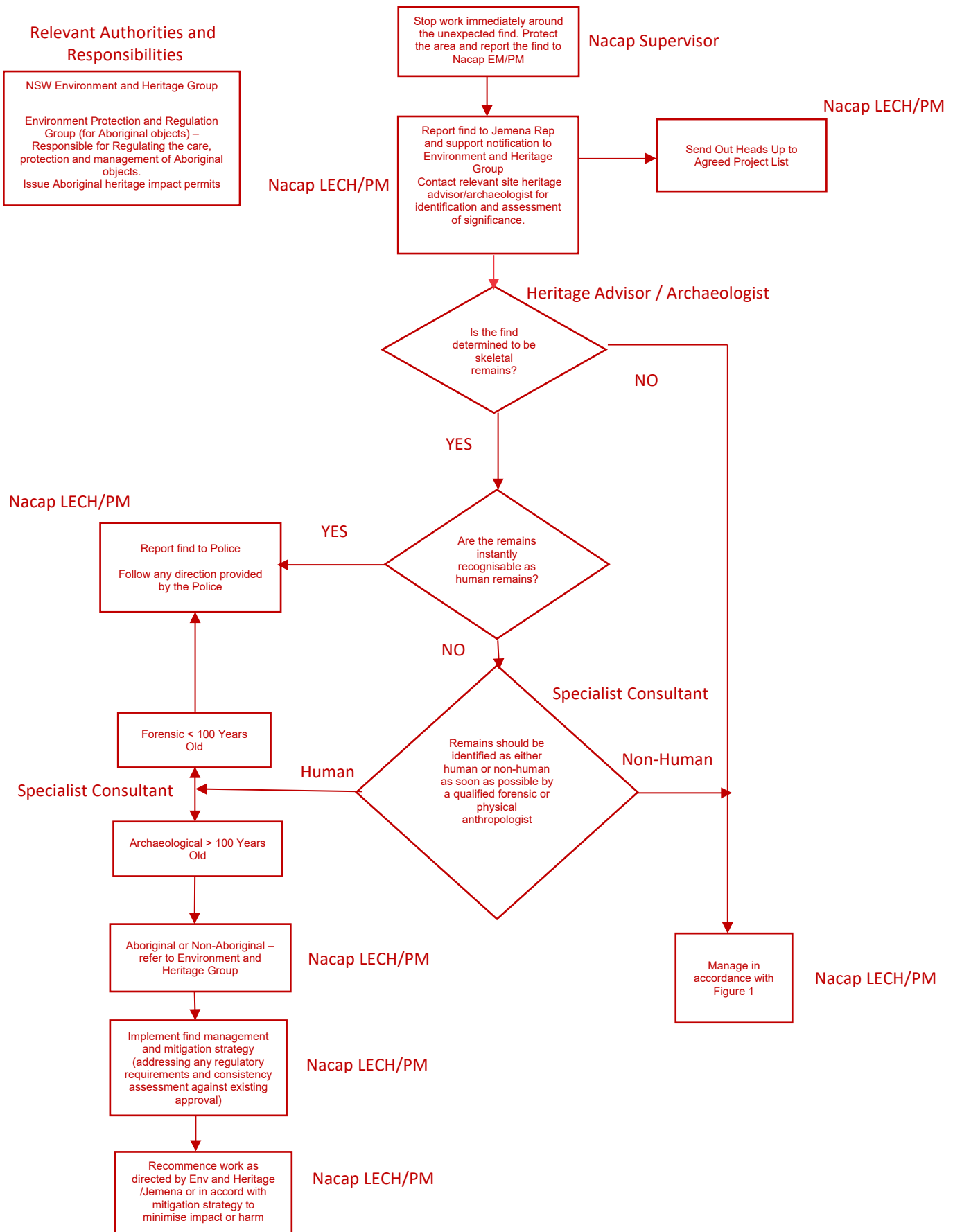
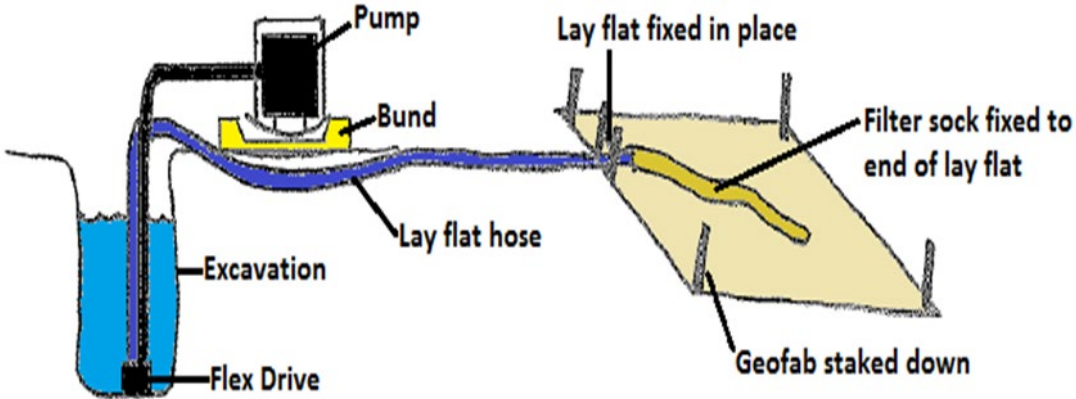

Figure 2 Unexpected Finds (Skeletal Remains) Procedure Flowchart



APPENDIX F DEWATERING AND WATER REUSE PROTOCOL

DEWATERING PROTOCOL AND REUSE PROTOCOL	
Purpose	<p>The purpose of the dewatering and water reuse protocol is to provide guidance to construction personnel regarding the proposed method for dewatering of excavations containing surface water run-off and ingress.</p> <p>Water that is surplus to construction needs and or water that is encountered during works which cannot be reused on site or released in accordance with the POEO Act (i.e., it does not meet release criteria or cannot be treated in situ), will be considered wastewater and be transported by a licenced transporter to a licenced facility for disposal.</p> <p>All wastewater will be managed in accordance with the Waste Management Plan (GAS-599-PA-EV-008).</p> <p>In the event the water is suspected to be contaminated refer to Appendix D.</p>
Scope	<p>This protocol is to be used for all dewatering during works.</p>
Protocol and Mitigation	<ol style="list-style-type: none"> 1. Ensure ESCP (Appendix C) measures are in place to reduce the volume of water in excavations 2. The LECH Manager or delegate shall undertake an assessment of the water to identify potential sources of contaminants and determine if further sampling testing and treatment is required. This will involve a visual inspection for contaminants and a field test of the water against the parameters described below. 3. Water meeting the release parameters can be dewatered otherwise the LECH Manager or delegate will determine appropriate storage/ treatment and disposal options. 4. For small quantities of water approved to be released that do not impact on safety or the conduct of works, first consideration shall be to allow the water to evaporate should weather conditions suit. 5. Next option will be reuse as dust suppression water via the use of a water cart(s) taking the water direct from the excavation to other areas of the construction site that may require dust suppression. 6. If direct release to ground for infiltration is undertaken, ensure that the dewatering arrangement is set up as generally presented in Figure 1 below. In this instance, the following shall be adhered to: <ul style="list-style-type: none"> • Pumps to be used are to be banded • During the pumping operation, an operator MUST remain on site at all times and monitor the operation of the pumping and release of water • The receiving environment should be grassed or vegetated and have capacity for water infiltration, ensure the outlet site has scour control and ESC as appropriate to the receiving environment. • The outlet hose is to be fitted with a sediment sock • Monitor the release to ensure ESC is adequate to the outflow of water. • THERE IS TO BE NO DISCHARGE DIRECT TO WATERWAYS – review the path of flow downstream to observe impacts and amend the ESC as required • IF IN DOUBT STOP WORK AND SEEK ADVICE FROM LECH MANAGER OR SUPERVISOR <p style="text-align: center;">Figure 1 – Dewatering to ground set up</p> 

Release and Reuse Parameters	Parameter	Criteria	Treatment
	Oil and grease	Non-Visible	
	pH	6.5 – 9.0	<p>Acid will be used to lower pH. As a guide, a dosage rate of approx. 500ml of acid (50% concentration of H₂SO₄) lowers pH of 7000L of water by approx. 1.5 pH.</p> <p>Lime will be used to raise the pH.</p> <p>Ensure good mixing to be effective and maintain monitoring to attain the desired pH.</p>
	Total Suspended Solids	<50mg/L	<p>If turbidity is greater than 50mg/L then it needs to have the sediment settled out using gypsum. Application rates should be based on the Blue Book and or as per manufacture’s specifications and product guides.</p> <p>Note that even application over water is essential for effective flocculation.</p>
Legislative Requirements	Refer to the CEMP Section 3.2 and CEMP Appendix C		
Relevant Authority	131 555 The Environment Line handles general inquiries about environmental issues and takes reports of pollution for which the EPA has regulatory responsibilities. Environment Line is a one-stop pollution and environmental incident reporting service provided by Environment and Heritage Group (EEG) and EPA.		

APPENDIX G ACID SULFATE SOILS MANAGEMENT PLAN

ACID SULFATE SOILS MANAGEMENT PLAN	
Purpose	<p>This Acid Sulfate Soils Management Plan (ASSMP) supports the purpose and objectives outlined in the Construction Environmental Management Plan CEMP (GAS-599-PA-EV-001), Soil and Water Management Plan SWMP (GAS-599-PA-EV-0070) and Waste Management Plan WMP (GAS-599-PA-EV-008).</p> <p>This ASSMP has been prepared to define the management processes required during construction to minimise the potential impacts associated with the disturbance of Acid Sulfate Soils (ASS) and Potential Acid Sulfate Soils (PASS) and to ensure that all reasonable and practical measures are undertaken to ensure that the activities across all works do not pollute the environment in a way which causes or may cause environmental harm.</p>
Scope	<p>This ASSMP is to be applied to all pipeline construction works associated with the Port Kembla Pipeline Project. The project area is described in Section 1.1 of this SWMP.</p>
Objectives	<p>The objectives of this ASSMP are to:</p> <ul style="list-style-type: none"> > promote general ASS awareness to project personnel through the provision of training and awareness > ensure the correct management and handling of ASS and PASS if encountered during pipeline construction works > minimise impacts to the surrounding land and water as a result of exposing ASS/PASS materials > implement effective treatment and management of ASS/PASS materials once disturbed to minimise the potential for generation and movement of acid leachate > ensure identification, isolation and protection of stockpiled ASS/PASS materials to avoid mixing with other soils and surface waters, and >
Legislative Requirements	<p>Protection of the Environment Operations Act 1997 (NSW) (POEO Act)</p> <p>The POEO Act provides the statutory framework for managing pollution in NSW, including the procedures for issuing licences for environmental protection on aspects such as waste, air, water, and noise pollution control.</p> <p>The Act also covers the requirements for waste generators in terms of storage and correct disposal of waste and establishes the waste generator as having responsibility for the correct management of waste, including final disposal.</p> <p>Protection of the Environment Operations (General) Regulation 2009</p> <p>The Regulation contains provisions relating to:</p> <ul style="list-style-type: none"> > environment protection licences, > the issuing of penalty notices under the Act and certain related environmental legislation, > the appropriate regulatory authority for certain type of activities, > notification of pollution incidents. <p>Protection of the Environment Operations (Waste) Regulation 2014</p> <p>Makes requirements relating to non-licensed waste activities and non-licensed waste transporting, for example the way in which waste must be stored or transported, reporting and record-keeping requirements. The regulation exempts certain waste streams from the full waste tracking and recordkeeping requirements and allows the EPA to approve the immobilisation of contaminants in waste.</p>
Guidelines	<ul style="list-style-type: none"> > <i>National Environment Protection (Assessment of Site Contamination) Measure 1999</i> > <i>NSW EPA (2014b). Waste Classification Guidelines Part 4: Acid sulfate soils (NSW EPA, 2014)</i> > <i>NSW EPA Sampling Guidelines (NSW EPA 2022)</i> > <i>Acid Sulfate Soils Manual (Acid Sulfate Soil Management Advisory Committee 1998)</i> > <i>Queensland Acid Sulfate Soil Technical Manual (QASSTM) Soil Management Guidelines (Department of Science, Information Technology, Innovation and the Arts) 2014</i>
Existing Environment	<p>The existing environment in relation to likelihood of encountering ASS/PASS based on the EA is described in Section 3.2.1 of this SWMP.</p> <p>Based on Section 3.2.1, and given the proposed construction methodology and shallow depths of excavation, it is unlikely that ASS/PASS will be encountered other than unexpected finds and when undertaking HDD works within Segment 1.1 and 1.2.</p>
Construction Methodology	<p>Pipeline construction will generally involve earthworks undertaken progressively in a linear fashion using a cleared CROW limited to approximately 20m in width. Clearing works will be undertaken by dozers, graders and excavators. Trenching works will generally be undertaken using excavators and for trenchless crossings the use of horizontal directional drilling.</p> <p>The welded pipeline will be lowered into the trench and the trench backfilled using excavators to optimise the extent of open excavations. Progressive reinstatement of the disturbed areas will follow. On this basis the stockpiling of excavation</p>

	<p>and backfill materials will be of small volumes and relatively short durations. Exposed and stockpiled subsoils topsoils will also be temporary and of short duration.</p>
<p>Construction Impacts</p>	<p>Potential impacts resulting from deeper excavation of soils that may contain ASS/PASS are that excavated soils may be exposed during temporary stockpiling/storage resulting in oxidation. Once oxidised, there is potential for development of sulfuric acid should the soil be exposed to moisture during rain events. It follows that runoff may transport water with lowered pH to surrounding lands resulting in potential impacts to surface and marine waters and existing groundcover.</p> <p>Additional potential impacts may exist during dewatering activities where rain ingress into the trench or groundwater has contacted soils containing ASS/PASS resulting in potential lowering of trench water pH. There is potential for the subsequent release to land and surface waters of trench water with lowered pH during dewatering.</p>
<p>Identification and Field Assessment</p>	<p>Indicators include soils with pH < 4; ‘rotten egg’ smell, unusually clear or milky green drain water with pH <5.5, extensive rust coloured drain iron stains on any drain surfaces or iron-stained drain water and ochre deposits; butter coloured jarosite present in surface spoil on any material excavated and left exposed or material showing yellow jarosite horizons or red iron oxide mottling.</p> <p>Potential acid sulfate soils are typically waterlogged estuarine sands or silty sands, mid to dark grey to dark greenish grey in colour, soft buttery consistency of a clay, pH neutral.</p>
<p>Management Measures</p>	<p>The priority for management of ASS during pipeline construction works will be to:</p> <ul style="list-style-type: none"> > Avoid disturbance of potential ASS/PASS where practicable. <p>Where disturbance is unavoidable, the desired management approach will aim to minimise the generation and movement of acid leachate and will include:</p> <ul style="list-style-type: none"> > Minimising disturbance of areas suspected to be ASS/PASS through optimised layout – excavate to the minimal extent practicable for safe works > Identification and delineation of areas of suspected or unexpected finds of ASS/PASS through field assessment > Staging of disturbance and excavation of suspected or unexpected finds of ASS/PASS such that potential effects on soils disturbed at any one time can be effectively managed > Prevent opportunities for oxidation through construction management of potential ASS/PASS locations and duration of stockpiling through minimising the time between trenching, lowering in and backfill/reinstatement > Implementation of alternative construction methodologies to minimise excavation required for pipeline construction such as horizontal directional drilling (HDD). <p>Where field assessment indicates the presence of ASS/PASS the affected area or section of trench is to be treated as a ‘Special Crossing’ and trigger a targeted construction methodology approach to reduce exposure and risk:</p> <ul style="list-style-type: none"> > Undertake further field screening assessment including soil texture and pH peroxide testing to confirm ASS/PASS <ul style="list-style-type: none"> o Field screening assessment using hydrogen peroxide (H₂O₂) should be performed at 0.25m intervals on excavation horizons in accordance with NSW Acid Sulfate Soils Manual (Acid Sulfate Soil Management Advisory Committee 1998) o Soils that record a field screening pH of below 4, following oxidation with H₂O₂ will be managed as acid sulfate soils > Ensure suitable areas within the CROW are identified to allow for contingency management and treatment of excavated ASS/PASS material > Monitor weather and surface water conditions - construction works during wet weather should be avoided in areas of suspected ASS/PASS unless conditions are such that surface water issues and the movement of leachate from stockpiles can be managed effectively within the CROW > Establish erosion and sediment controls for the management of overland flows, diverting clean water from entering the CROW and management of surface waters within the CROW which may be affected by ASS/PASS > Use guard layers of lime in advance of trenching in areas of known or suspected ASS/PASS to cover the proposed trench line and trench spoil stockpile zone > HDD drilling fluids pH will be monitored in accordance with the HDD Management plan and ameliorated accordingly to neutralise and maintain performance of the drilling fluid > Minimise the duration of stockpiled materials. Stockpiles that exceed the following durations (based on QASSTM) will be treated: <ul style="list-style-type: none"> o Coarse (sands to loamy sands with clay content ≤ 5%) Overnight - (18 hours) o Medium (sandy loams to light clays 5–40% clay) 2.5 days (70 hours)

	<ul style="list-style-type: none"> ○ Fine (medium to heavy clays and silty clays.≥ 40%) 5 days (140 hours) > Treat stockpiles/HDD cuttings containing ASS/PASS with lime in situ to neutralise prior to backfill and / or disposal. Neutralisation of ASS involves mixing of finely crushed Agricultural lime (Aglime) or other liming agents with a neutralising value of at least 90 with the excavated material to ensure the potential of ASS to generate acid is minimised or prevented. > Based on the small volumes of excavations and short duration of stockpiling, the liming rate for excavated materials to be returned to the trench will be 10kg/tonne of excavated material (based on 0.2% S).. > Surplus spoil that is to be transported off site for disposal will be subjected to laboratory soil testing in accordance with the NSW ASS Manual. Calculation of the quantity of lime required for treatment will be calculated based on rates recommendations made by the laboratory with which the analysis was undertaken, however it should be noted that the following formula from the NSW ASS Manual may also be used for guidance: <ul style="list-style-type: none"> ○ Liming rate kg/tonne material = (Oxidisable S% x 30.59) x 1.5 > Validation of ASS treatment of surplus material will be based on: <ul style="list-style-type: none"> ○ Minimum of 2 samples per batch (<100m³) of stockpiled treated material ○ Samples to be tested using the SCR suite with full acid base accounting including retained acidity. ○ Performance criteria shall be: <ul style="list-style-type: none"> ▪ No single sample shall exceed a net acidity of 18 mol H+/tonne (0.03% S). ▪ Field screening to be undertaken to confirm pH post treatment is > 6.5 (but no higher than 8.5) > Any ASS/PASS material following neutralisation that is surplus to project needs will be disposed of in accordance with NSW EPA (2014b). Waste Classification Guidelines Part 4: Acid sulfate soils (NSW EPA, 2014) > An ASS/PASS treatment register will be maintained to record sections of the ROW that have been treated and will include liming quantity, liming rate and the soil volumes treated. <p>To ensure the pipeline construction meets applicable standards, the trench may need to be dewatered to remove any water which has collected during the time the trench has been open. The pipeline works will discharge non-contaminated acidic and/or brackish groundwater/trench water from the open trenches and bell holes to adjacent land (with permission/approval from relevant landholders. The following management measures are applicable for trench water:</p> <ul style="list-style-type: none"> > Minimise activation of PASS by minimising duration and extent of dewatering activities, such as dewatering immediately prior to installation of pipe and minimise the time that trench sections and bell holes are open. > Water in known ASS/PASS areas should be tested and must meet the following parameters before release: <ul style="list-style-type: none"> ○ pH between 6.0 and 9.0 ○ Electrical conductivity of <3000µS/cm ○ No visible oil, grease, or other contaminants > Water will not be discharged to waterways. > Discharge should be to low gradient, stable areas and be undertaken in accordance with landholder requirements using measures to prevent scour or erosion. Visual monitoring during land discharge should be undertaken to ensure water does not enter existing waterways.
<p>Monitoring</p>	<p>Monitoring will be undertaken in accordance with Section 6 of this SWMP.</p>
<p>Incident Reporting</p>	<p>Any environmental incidents and non-conformance will be reported and managed in accordance with CEMP Section 7.1.</p>
<p>POEO Act Reporting</p>	<p>In accordance with the Protection of the Environment Operations Act 1997 (POEO Act) the Environment Protection Authority (EPA) must be notified of pollution incidents that cause or threaten material harm to the environment. POEO Act reporting will be undertaken in accordance with the CEMP Section 7.2</p> <p>EPA 131 555</p>

	<p>The Environment Line handles general inquiries about environmental issues and takes reports of pollution for which the EPA has regulatory responsibilities. Environment Line is a one-stop pollution and environmental incident reporting service provided by Environment and Heritage Group (EEG) and EPA.</p>
Records and Reporting	<p>In addition to the records identified in Section 7 of the SWMP the following records are expected to be generated in relation to this ASSMP and monitoring:</p> <ul style="list-style-type: none">> ASS/PASS Treatment Register> Materials Tracking Register> Disposals Register